

# JBG<sup>HT</sup>

## INSTALLER MANUAL

HEAT PUMP



ZHHS-01-10K-R290-V5-M | ZHHS-01-15K-R290-V5-M

### CAUTION!

IT IS ESSENTIAL TO READ THE  
INSTRUCTION MANUAL BEFORE USE!

JBG-2 SP. Z O.O. RESERVES THE RIGHT TO MAKE CHANGES TO THE PRODUCTS AND INFORMATION CONTAINED IN THE DOCUMENTATION WITHOUT NOTICE. ALL RIGHTS RESERVED.

Translation of the original manual



## TABLE OF CONTENTS

<b>1. CHARACTERISTICS</b> .....	<b>5</b>
1.1. Idea of action for the heat pump .....	6
<b>2. SAFETY</b> .....	<b>6</b>
2.1. Marking system .....	7
2.2. Before first use .....	8
2.3. Important warnings .....	8
2.4. Risks as a result of product changes .....	9
2.5. Risks of personal injury and property damage as a result of improper maintenance and repair or failure to do so .....	9
2.6. Risk related to improper use .....	10
2.7. Risk of burn injury .....	10
2.8. Risk of malfunction due to incorrect electrical supply .....	10
2.9. Risk of environmental contamination from leaking refrigerant .....	10
<b>3. DOCUMENTATION</b> .....	<b>10</b>
3.1. Description of Monoblock pump operation .....	10
3.1.1. Product conformity (CE marking) .....	11
3.2. Schematic of heat pump operation .....	11
3.2.1. Pump operation in heating mode .....	11
3.2.2. Pump operation in cooling mode .....	11
3.2.3. Heat pump operation envelope .....	12
3.3. Pump design .....	13
3.3.1. ZHHS-01-10K-R290-V5 Pump .....	13
3.3.2. ZHHS-01-15K-R290-V5 Pump .....	16
3.3.3. Indoor unit (Controller) Option 1 .....	18
3.3.4. Indoor unit Hydrobox Option 2 .....	20
3.3.5. Indoor unit Hydrotower Option 3 .....	22
3.4. Standard components .....	24
3.5. Accessories .....	24
<b>4. SAFE TRANSPORTATION, INSTALLATION AND STORAGE</b> .....	<b>24</b>
4.1. General Guidelines .....	24
4.2. Location of the pump in relations to noise emission .....	25
4.3. Transportation .....	25
4.4. Unpacking the product .....	26
4.5. Storage .....	26
4.6. Mechanical installation and mounting .....	26
4.6.1. Setting up the outdoor unit – general guidelines .....	26
4.7. Defrost mode .....	28
4.8. Electrical installation .....	29
4.8.1. Requirements .....	29
4.8.2. Diagrams of the electrical system .....	32
4.9. Hydraulic system .....	35
4.9.1. Requirements .....	35
4.9.2. Hydraulic system diagrams .....	37
4.9.3. Diagram of the refrigeration system .....	41

4.9.4. Water supply system	41
4.9.5. Filling up and venting the system	42
4.9.6. Installing the DHW sensor	42
4.9.7. Initial startup	42
4.10. Installing the Internet module	43
4.10.1. WiFi connection at the User's site (Wireless network as an output to the Internet)	43
4.10.2. Cable connection at the User's site (Cable network as an output to the Internet)	43
4.10.3. Cable connection at the User's site (to check Internet access)	44
4.10.4. WiFi Configuration	44
<b>5. starting up the heat pump</b>	<b>46</b>
5.1. Controller Main Screen	46
5.2. Menu Icons	47
5.3. Turning on and off	47
5.4. CH and DHW temperature settings	47
5.5. Logging in	48
5.6. Options and settings	48
5.6.1. CH/DHW Calendar	48
5.6.2. Calendar	48
5.6.3. Setting a schedule	49
5.6.4. Vacation Periods	49
5.6.5. Week view	49
5.6.6. Special days	49
5.6.7. Date and time	50
5.6.8. Manufacturer	50
5.6.9. Service	50
5.7. Quick Guide	50
<b>6. SETTINGS AVAILABLE TO THE SERVICE TECHNICIAN</b>	<b>57</b>
6.1. Weather control	57
6.2. Mixer heating curve	57
6.3. Procedure for performing evaporator defrosting	58
<b>7. MAINTENANCE, INSPECTION AND REPAIR</b>	<b>58</b>
7.1. Maintenance notes	58
7.2. Safety parameters	59
7.3. Disassembly and disposal	59
7.4. Error codes	59



1. CHARACTERISTICS

MONOBLOCK HEAT PUMP					
ZHHS-01-10K-R290-V5-M / ZHHS-01-15K-R290-V5-M					
Performance data – heating (EN 14511)					
		ZHHS-01-10K-R290-V5-M	ZHHS-01-15K-R290-V5-M		
1	A7/W35	Power range (min-max) <sup>1</sup>	kW	3,38 ÷ 9,86	5,35 ÷ 14,7
		Partial load <sup>1</sup>	kW	6,60	8,70
		Power consumption <sup>1</sup>	kW	1,45	1,64
		COP <sup>1</sup>		4,56	5,29
2	A7/W45	Power range (min-max) <sup>2</sup>	kW	3,00 ÷ 8,89	5,22 ÷ 14,81
		Partial load <sup>2</sup>	kW	5,29	8,58
		Power consumption <sup>2</sup>	kW	1,44	2,15
		COP <sup>2</sup>		3,67	3,99
3	A7/W55	Power range (min-max) <sup>3</sup>	kW	2,88 ÷ 8,51	4,92 ÷ 13,76
		Partial load <sup>3</sup>	kW	5,50	9,20
		Power consumption <sup>3</sup>	kW	2,00	2,89
		COP <sup>3</sup>		2,75	3,19
4	A2/W35	Power range (min-max) <sup>4</sup>	kW	3,00 ÷ 9,01	4,67 ÷ 13,65
		Partial load <sup>4</sup>	kW	3,00	4,67
		Power consumption <sup>4</sup>	kW	0,67	0,98
		COP <sup>4</sup>		4,48	4,75
5	A-7/W35	Maximum power <sup>5</sup>	kW	6,80	11,17
		Power consumption <sup>5</sup>	kW	2,47	4,08
		COP <sup>5</sup>		2,75	2,73
Cooling data					
Pump type		air / water			
Refrigerant type		R290			
Refrigerant amount		kg	0,55      0,8		
Maximum working pressure		bar	26		
Compressor type		inverter scroll			
Oil		PAG PZ46M			
Adjustment type		electronic			
Heating + DHW					
Minimum working pressure		bar	1,0		
Maximum working pressure		bar	3,0		
Rated flow		m <sup>3</sup> /h	117      1,48		
External operating temperature range		°C	from -20 to +35		
Feed water temperature		°C	from +20 to +65		
Physical dimensions					
Depth x width x height		mm	505 x 1155 x 935      505 x 1155 x 1530		
Weight		kg	132      166		
Water connections		G 5/4 "			
Sound power level		dB	59      61		
Air flow		m <sup>3</sup> /h	3500      6000		
Electrical data					
Electrical connection		V/Ph/Hz	400 / 3~ / 50		
Protection rating		IP24			
Electric heater power (with the option of hydrobox / hydrotower)		kW	3 / 6 / 9		
Maximum starting current		A	10      13		
Fan power consumption		W	50      100		
Number of fans			1      2		
Fan rotor speed		RPM	700		
<b>SCOP</b>		<b>w35 5,04 / w55 3,92    w35 5,39 / w55 3,98</b>			
<b>Energy efficiency class</b>		<b>w35 A+++ / w55 A+++</b>			
Device with a regulator – feed temperature 35°C / 55°C					

- ① Heating temperature: water I/O temperature: 30°C / 35°C, Ambient temperature: DB 7°C / WB 6°C;
- ② Heating temperature: water I/O temperature: 40°C / 45°C, Ambient temperature: DB 7°C / WB 6°C;
- ③ Heating temperature: water I/O temperature: 50°C / 55°C, Ambient temperature: DB 7°C / WB 6°C;
- ④ Heating temperature: water I/O temperature: 30°C / 35°C, Ambient temperature: DB 2°C / WB 1°C;
- ⑤ Heating temperature: water I/O temperature: 30°C / 35°C, Ambient temperature: DB -7°C / WB -8°C;

## 1.1. Idea of action for the heat pump

The principle of the heat pump is to collect heat from the so-called low-temperature lower source (-20°C to +35°C) and transfer the heat to the high-temperature upper source (the central heating and DHW system). This process is carried out with electricity supplied to drive the compressor.

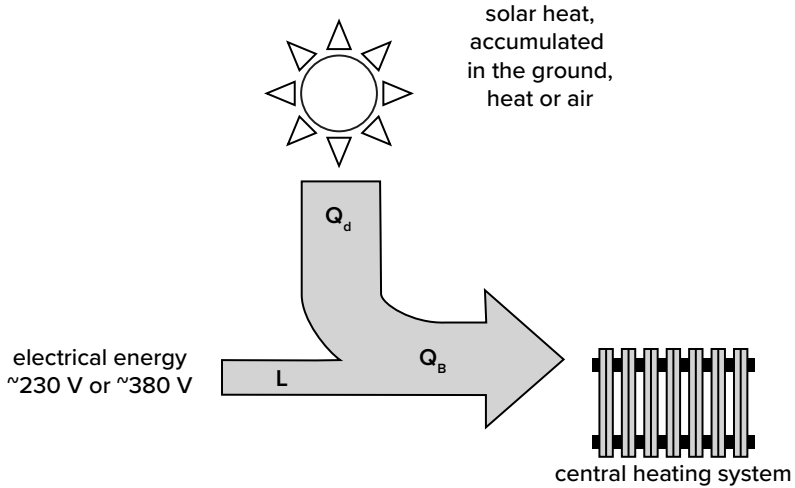

Fig. 1. Principle of operation of a heat pump

In heat pump systems, it is possible to use both the hot side (upper source), e.g. for heating purposes, and the cold side (lower source - air), e.g. for air conditioning or refrigeration. In the heat pump settings, we can select the following modes of operation:

- Plant – central heating,
- DHW – domestic hot water,
- Plant + DHW – central heating + domestic hot water,



## 2. SAFETY



**Before using the device, it is essential to read the instruction manual. Failure to do so may lead to improper operation of the device, malfunction, and may endanger the lives of those operating the device.**

- 1) The manual contains rules for handling the product, both before its first start-up and during use.
- 2) The content highlights descriptions of situations to which special attention should be paid.
- 3) If the following content is not adhered to, the product may be damaged even irreparably.
- 4) The manual is an integral part of the unit, it should be delivered to the user together with the equipment. The manual should be retained for reuse.
- 5) If the device is resold or possession is otherwise transferred to another party, make sure that the manual is transferred with the device.
- 6) If any damage is detected during transport - the device must not be connected to the mains electricity(contact service).
- 7) Use the device in accordance with the purpose for which it was designed.
- 8) Before connecting the device, check the correctness of the electrical connections and the effectiveness of the grounding system.
- 9) If the warranty seals are removed, inform the service center.
- 10) Children and persons with a diagnosed disability limiting physical, sensory or mental abilities may use the heat pump only under the supervision of a person to whom the limitations listed in this section do not apply.

### 2.1. Marking system



Attention - important content. Procedure to which special attention should be paid.



Caution - a task that requires special attention. Very important information regarding use.



Electricity - information about the electrical system, tasks related to connecting the device to the electrical network.



Gloves - activities that require additional personal protection.



A ban placed on electrical and electronic devices reminding the public not to throw items in trash containers.



Caution - hot surfaces.



Caution - moving parts.



Warning - harmful substance, risk of suffocation



Warning – risk of explosion.



Warning – sudden (loud) noise



Warning – automatic activation



Warning – low temperature



Warning of fire hazard substances in combination with R290 refrigerant.



Fire, open flame and smoking prohibited.

*Tab. 1. Marking system used*

### 2.2. Before first use



**The device should not be accessed by unqualified, outsiders.**

Inside the device there are components powered by electric voltage, which are life-threatening in case of direct contact. Any work in the vicinity of the electrical board must be carried out only by qualified and authorized personnel with the appropriate professional authorizations and in compliance with health and safety rules.

The electrical connection must be made by an electrician with the appropriate qualifications.

Installation, assembly and commissioning work should be carried out by a person with appropriate qualifications.

Before opening the housing, disconnect the electrical power supply.

For installation and maintenance, use appropriate tools and direct protection equipment.

External surfaces of apparatus and equipment inside the unit may be hot and cause burns.





2.3. Important warnings



The device is not intended for use by children.



Read this manual before use.



Assembly, disassembly, installation work and maintenance of the device must be performed by qualified personnel. It is forbidden to make any changes to the structure of the unit. Failure to do so may result in injury to persons or damage to the unit.

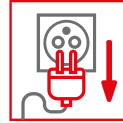

Before performing any operations on the unit, make sure that the electrical power to the heat pump unit is turned off. If the power cord becomes loose or damaged, make sure to always call a qualified person to repair it.

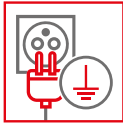

The power supply to the device must be grounded.



The device should be kept away from environments that are flammable or corrosive.



A dedicated electrical connection should be used to power the device, otherwise, failure may occur.



Do not touch the grille of the air exhaust and outlet.



Do not direct a stream of water directly on the device. Power leakage or product failure may occur.

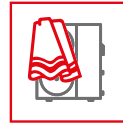

When the device is in operation, never cover it with clothes, cloth or other material that blocks the ventilation of the product, as this may lead to low efficiency or even malfunction of the device.

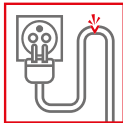

If the power cord is damaged, take the device out of service and call a qualified person to repair it.



It is mandatory to use the appropriate heat pump circuit breaker and make sure that the power supply complies with the specifications. Otherwise, the unit may be damaged.

Tab. 2. Important warnings

## 2.4. Risks as a result of product changes



- Never remove, bridge or block safety devices.
- Do not tamper with safety devices.
- Do not make any changes to the product, to the supply lines, to the heating circuit safety valve.

## 2.5. Risks of personal injury and property damage as a result of improper maintenance and repair or failure to do so



- Perform maintenance annually before the heating season.
- Never perform repairs or maintenance work yourself.
- Have an authorized installer perform repairs and maintenance work.
- Adhere to designated maintenance intervals.

## 2.6. Risk related to improper use



**Improper use can lead to damage to the heat pump, danger to those operating the unit and others in the vicinity.**

## 2.7. Risk of burn injury



The pipes from the water exchanger located in the heat pump should be carefully insulated, since the maximum possible temperature of the pipes is 75 degrees Celsius.

## 2.8. Risk of malfunction due to incorrect electrical supply



Avoid interference with the operation of the product, the electrical supply should be within the specified limits:

- 3-phase: ~400 V (+10%), 50 Hz

## 2.9. Risk of environmental contamination from leaking refrigerant



The product contains refrigerant R290 called natural refrigerant gas. The GWP rating of this refrigerant is 3.



Only an installer with the proper licenses issued by the manufacturer and protective equipment may perform installation and maintenance work.



Installation of the unit must be a minimum of 1m away from windows, doors, lighting ducts, roof windows, hatches, drain pipes and ventilation ducts due to possible leakage of flammable gas.



In case of repairs, do not use sparking devices or other devices that can cause an ignition of the refrigerant.



Condensate drainage must not be introduced into the sewer system, as it may create an explosive atmosphere.



Do not use open flames or other devices that can heat up the temperature to 370°C in the heat pump environment.

In the event of a leak or suspected leak of refrigerant, immediately turn off the unit. Then remove any equipment from the environment that may be a potential source of fire and contact the service department.



### 3. DOCUMENTATION

#### 3.1. Description of Monoblock pump operation

A monobloc heat pump is a compact unit containing all the components of the refrigeration system and the heat exchanger in which the heating medium for central heating and domestic water is heated.

The outdoor unit contains refrigeration components including the fan, evaporator and compressor, condenser, valves and auxiliary fittings. The compressor (5) pumps hot gas which goes to the four-way valve which performs the function of switching heating/cooling modes (defrost), then the gas goes to the condenser (6) in which it gives up heat to the medium (water, glycol) which then goes to the facility for heating or hot water. The condensed, subcooled medium in the form of liquid goes to the electronic expansion valve (EEV)(4), where expansion takes place, then goes to the lower heat source (evaporator)(1) the medium takes heat from the environment this is done by air flow through a fan forced exchanger (2).

The refrigerant in the evaporator evaporates and returns in the gas fraction to the compressor.

The indoor installation is equipped with a three-way valve (3-WAY), which distributes the heated medium for central heating or hot water purposes (in priority). In the case of very low ambient temperatures and the required higher temperature for heating purposes, an electric heater (with the option of hydrobox / hydrotower) is additionally used to raise the temperature parameter of the medium, which also has a protective function in the event of failure of the refrigeration system to ensure a positive temperature and minimize the risk of freezing of the medium in the condenser.

#### 3.1.1. Product conformity (CE marking)

CE marking or CE marking placed on a product is a manufacturer's declaration that the marked product conforms to the directives so-called New Approach of the European Union.

The declaration of conformity is available for inspection from the manufacturer.

#### 3.2. Schematic of heat pump operation

##### 3.2.1. Pump operation in heating mode

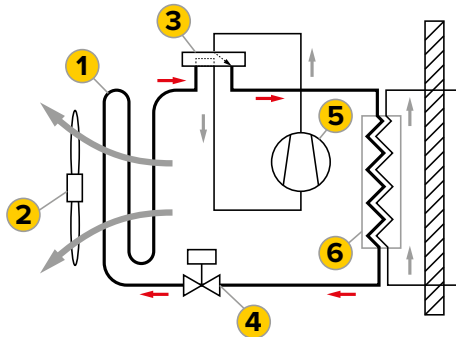

Fig. 2. Heat pump heating mode

- 1 Heat exchanger – evaporator,
- 2 Fan,
- 3 Four-way valve,

- 4 Electronic expansion valve,
- 5 Compressor,
- 6 Heat exchanger – condenser.

## INSTRUCTION MANUAL – HEAT PUMP

The heat pump uses a natural refrigerant which is R290 or Propane.

Table 3 shows the dedicated gas quantity for JBG-2 pump systems

DATA	ZHHS-01-10K-R290-V5	ZHHS-01-15K-R290-V5
Information on the substance used	Natural gas	Natural gas
Type of factor	R290	R290
GWP rating for R290 refrigerant	3	3
Amount of refrigerant in PC circuit	0.55 kg	0,8 kg

Tab. 3. Dedicated amount of refrigerant

### 3.2.2. Heat pump operation envelope

The heat pump is able to operate under certain conditions. Approaching the limits may cause it to go outside the operation envelope, so in such a case safety mechanisms are activated. In the event of going outside the operation envelope, the unit is shut down.

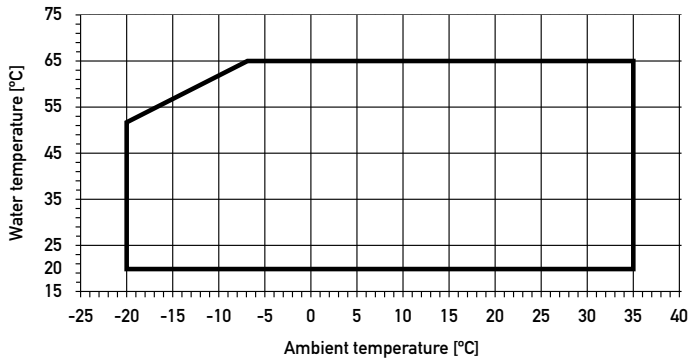

\*Applies to models:

ZHHS-01-10K-R290-V5-M

ZHHS-01-15K-R290-V5-M

Fig. 3. Heat pump operation envelope in heating mode



3.3. Pump design

3.3.1. ZHHS-01-10K-R290-V5 Pump

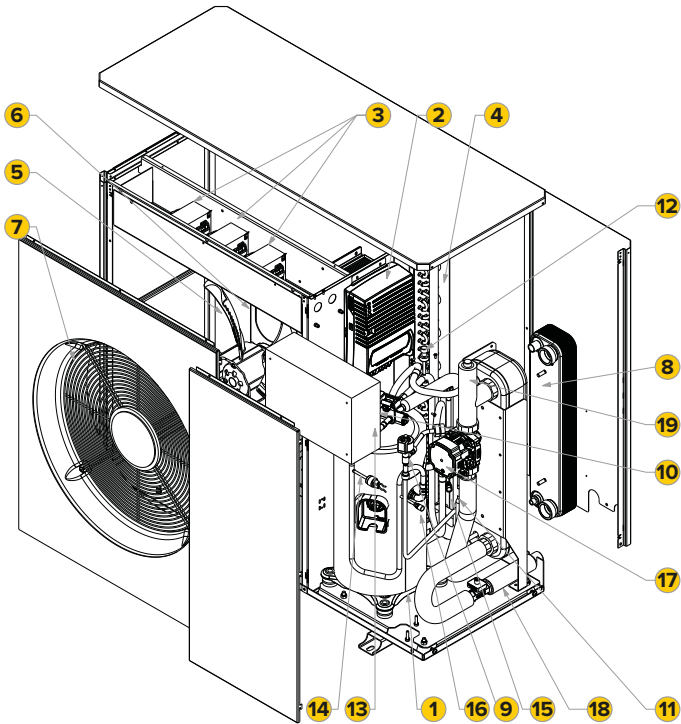

Fig. 4. Design of the heat pump outdoor unit ZHHS-01-10K-R290-V5

1	Scroll compressor	11	Dehydrator filter
2	Compressor inverter	12	LP Pressure transmitter
3	Choke coil	13	HP Pressure transmitter
4	Evaporator	14	HP Pressure switch
5	Fan	15	LP Service port
6	Fan support	16	HP Service port
7	Fan mesh	17	Circulation pump
8	Condenser	18	Flow sensor
9	Electronic expansion valve EEV	19	Vent
10	Four-way valve		

Tab. 4. Description of the marked parts of the heat pump outdoor unit

Front view



Photo 1. Picture of the heat pump front view

Rear view



Photo 2. Picture of the heat pump rear view

**3.3.1.1. External dimensions**

Front view

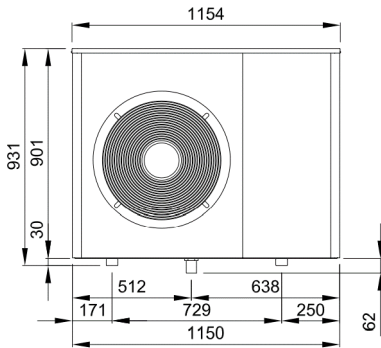

Fig. 5. External dimensions of the heat pump front view

Side view

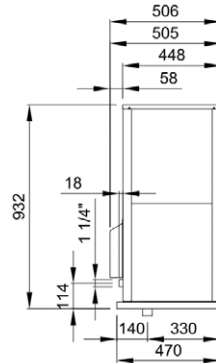

Fig. 6. External dimensions of the heat pump side view

Rear view

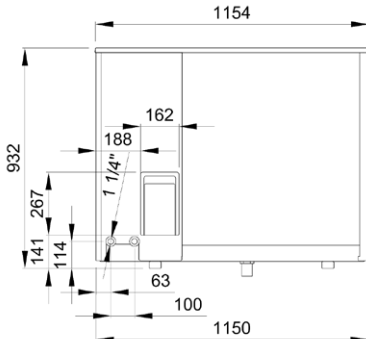

Fig. 7. External dimensions of the heat pump rear view

Bottom view

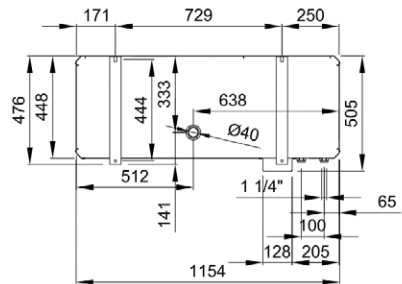

Fig. 8. External dimensions of the heat pump bottom view



**3.3.2. ZHHS-01-15K-R290-V5 Pump**

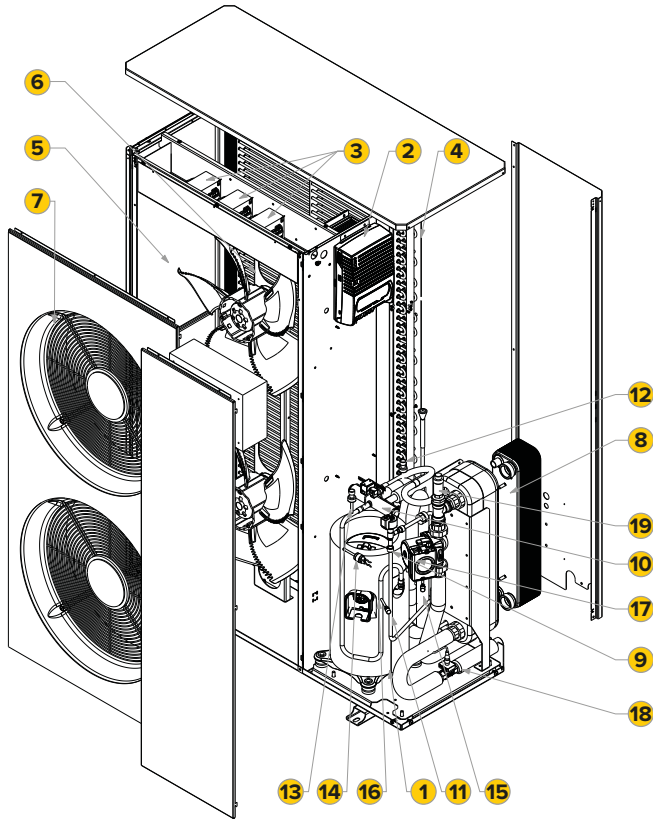

Fig. 9. Design of the ZHHS-01-15K-R290-V5 heat pump outdoor unit

1 Scroll compressor	11 Dehydrator filter
2 Compressor inverter	12 LP Pressure transmitter
3 Choke coil	13 HP Pressure transmitter
4 Evaporator	14 HP Pressure switch
5 Fan	15 LP Service port
6 Fan support	16 HP Service port
7 Fan mesh	17 Circulation pump
8 Condenser	18 Flow sensor
9 Electronic expansion valve EEV	19 Vent
10 Four-way valve	

Tab. 5. Description of the marked parts of the heat pump outdoor unit

Front view



Photo 3. Picture of the heat pump front view

Rear view



Photo 4. Picture of the heat pump rear view

**3.3.2.1. External dimensions**

Front view

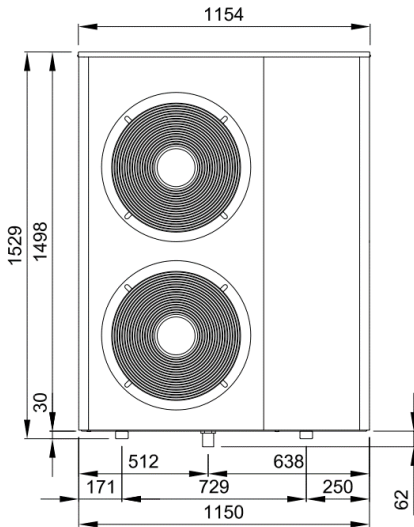

Fig. 10. External dimensions of the heat pump front view

Side view

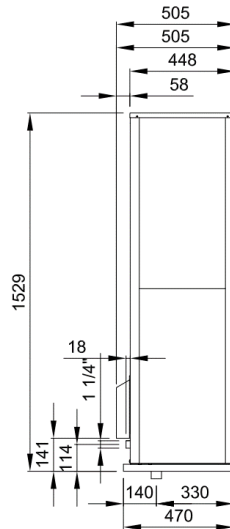

Fig. 11. External dimensions of the heat pump side view





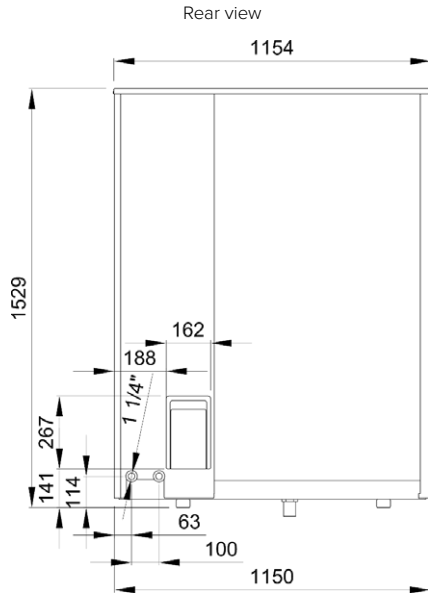

Fig. 12. External dimensions of the heat pump rear view

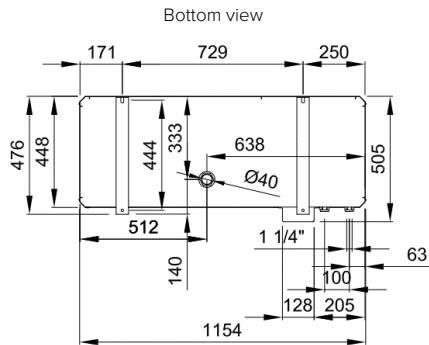

Fig. 13. External dimensions of the heat pump bottom view

**3.3.3. Indoor unit (Controller) Option 1**

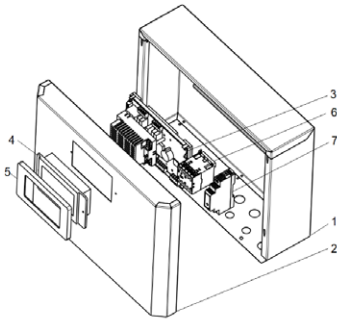

Fig. 14. Design of heat pump indoor unit

1	Rear controller case
2	Front controller case
3	Control board
4	pGDx display screen
5	pGDx display screen frame
6	Contactor
7	24V power supply

Tab. 6. Description of marked parts of the heat pump indoor unit

**3.3.3.1. External dimensions**

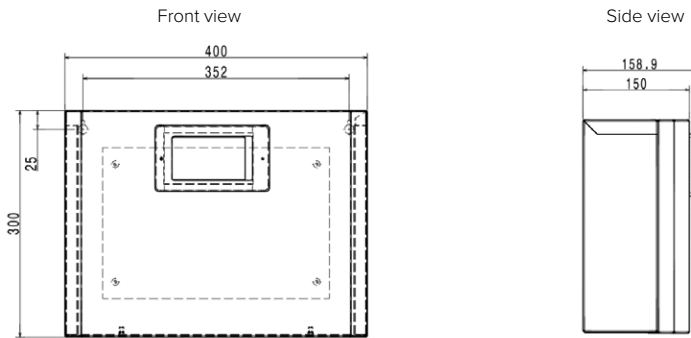

Fig. 15. External dimensions of the controller case front view



**3.3.4. Indoor unit Hydrobox Option 2**

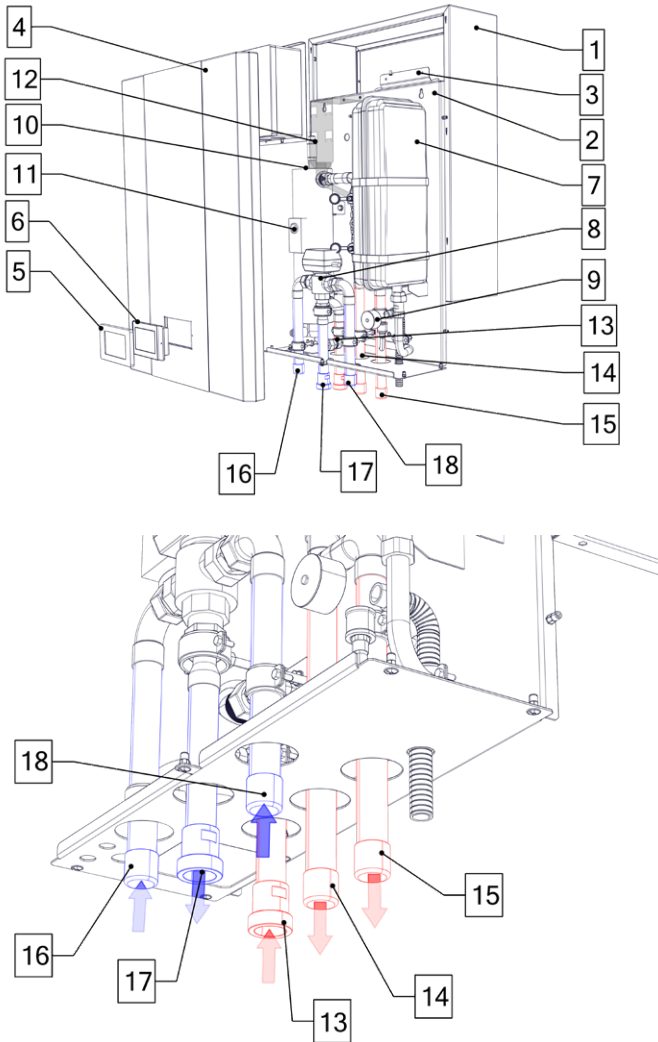

Fig. 16. Diagram of the hydraulic module

1	Casing	10	Electric heater
2	Mounting panel	11	Safety thermal switch
3	Mounting bracket	12	Automated vent
4	Control box	13	DHW return
5	pGDX screen display frame	14	CH power supply
6	pGDX screen display	15	DHW power supply
7	Diaphragm vessel	16	CH return
8	3-way valve	17	HP return
9	Pressure gauge – safety bar	18	HP feed

Tab. 7. Description of the marked parts of the Hydrobox

### 3.3.4.1. External dimensions

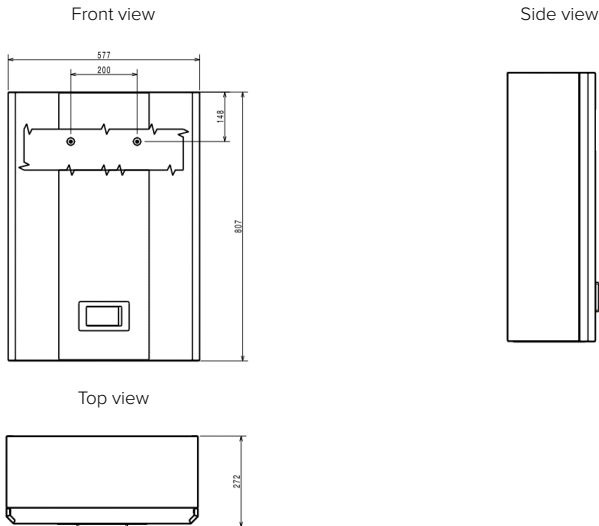

Fig. 17. External dimensions of the hydraulic module



3.3.5. Indoor unit Hydrotower Option 3

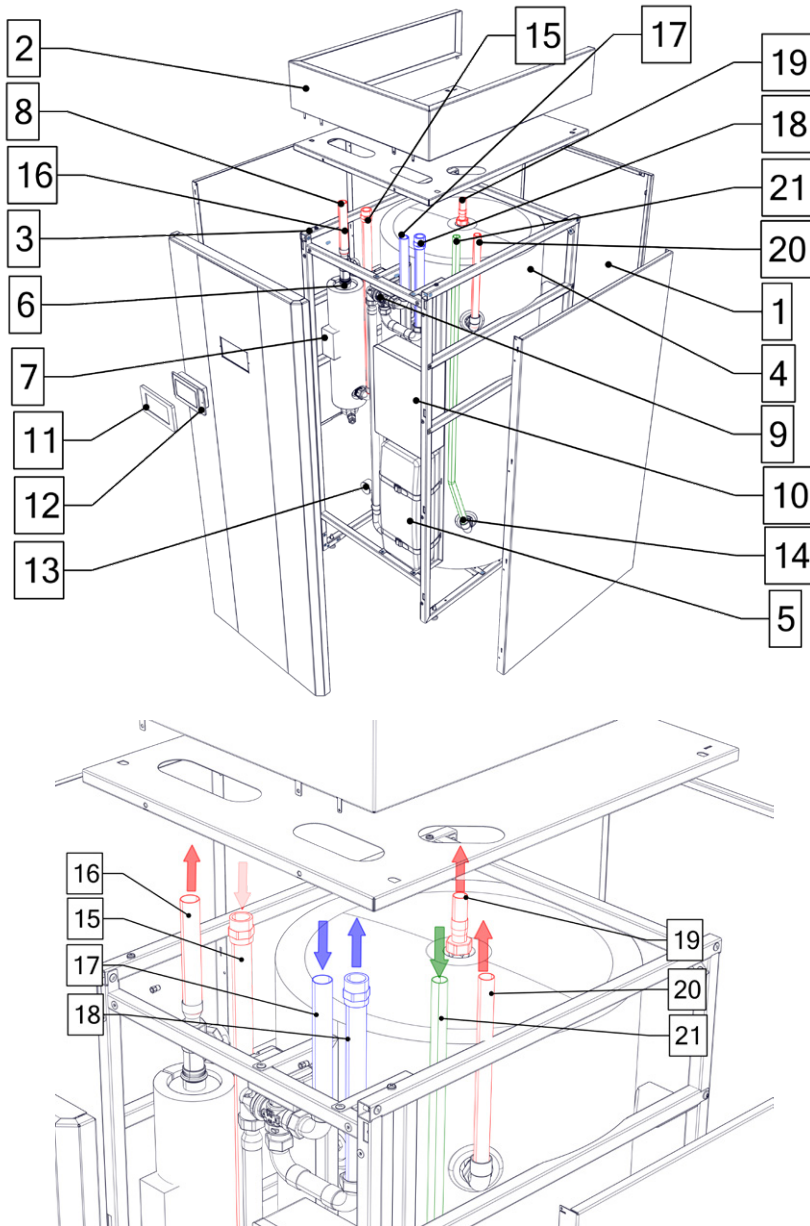

Fig. 18. Diagram of the hydraulic tower

1	Casing	12	pGDX display screen
2	Top cover	13	Pressure gauge – safety bar
3	Mounting frame	14	DHW discharge valve
4	DHW tank 200L	15	HP power supply
5	Diaphragm vessel	16	CH power supply
6	Electric heater	17	CH return
7	Safety thermal switch	18	HP Return
8	Automated vent	19	DHW power supply
9	3-way valve	20	DHW circulation
10	Controller	21	Cold domestic water supply
11	pGDX display screen frame		

Tab. 8. Description of the marked parts of the Hydrotower

### 3.3.5.1. External dimensions

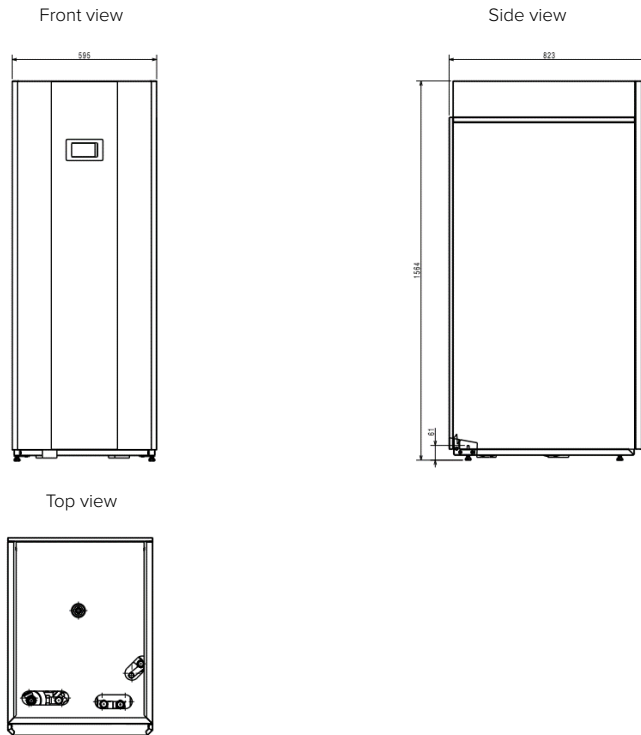

Fig. 19. External dimensions of hydraulic tower



**3.4. Standard components**

Picture					
Component name	Scroll compressor	Electronic expansion valve	Frequency inverter	Brushless fan	PWM pump
Picture					
Component name	Controller	Plate heat exchanger	Lamellar evaporator	Flow meter	

Tab. 9. Standard components used in the heat pump

**3.5. Accessories**

Picture				
Component name	AC Contactor and thermal relay	Electric heater	Diaphragm vessel (5l)	Three-way valve

Tab. 10. Optional components used in the heat pump

### 4. SAFE TRANSPORTATION, INSTALLATION AND STORAGE

#### 4.1. General Guidelines

- 1) Installation activities must be carried out only by qualified installers with appropriate authorizations (heating installers, sanitary installers, refrigeration technicians (in case of interference with the refrigeration system). Otherwise, there may be a danger to health and life.
- 2) The staff is obliged to act in accordance with the applicable rules of occupational health and safety.
- 3) Electronic and electrical work may be performed only by authorized personnel.
- 4) Service work can only be carried out through the pump manufacturer's service team or external service on behalf of the manufacturer. Otherwise, you risk losing the warranty.
- 5) Note that the air for the heat pump is drawn from the rear of the unit, while it is blown out by the unit's fans. This implies the need to exercise every care in the correct positioning of the outdoor unit outside the building.
- 6) Follow the distances shown in Table 9 to ensure sufficient airflow and allow for maintenance work.
- 7) Make sure there is enough space for the installation of heating cables.
- 8) The heat pump is suitable for both ground mounting. Installation on a flat roof is possible, but check the current building and ceiling strength regulations. Adequate condensate drainage must be provided. Do not install the product on wooden-framed buildings and lightweight roofs. Installation on a sloping roof is not allowed.
- 9) The air temperature at the outlet is about 5°C lower than the ambient temperature. Therefore, under certain weather conditions, this can cause ice formation. Therefore, do not choose a location where the air outlet is near sidewalks, paving surfaces and drain pipes. Keep the heat pump at an appropriate distance from the ground.
- 10) Do not expose the outdoor unit to polluted, dusty and corrosive air.
- 11) Maintain clearance from vents.
- 12) Maintain distance from trees. Leaves can contaminate the heat exchanger of the heat pump and cause it to stop or be damaged.
- 13) Pay attention to noise emissions. Choose a place that is easily accessible from the point of view of carrying out maintenance work.
- 14) Avoid sucking in the air blowing out of the heat pump outlet.
- 15) Ensure that water does not collect on the ground, water must penetrate into the ground without obstruction.
- 16) Choose a place where large amounts of snow do not accumulate in winter. If this is not possible, remove snow regularly from the air inlet/outlet grille and around the product.
- 17) Choose a location where high winds do not affect the heat pump, especially the air intake. If possible, position the unit transverse to the main wind direction.
- 18) Safety area:  
Due to the fact that the product contains R290 refrigerant. The installation site must be at least 1m away from potential ignition sources: electrical switches, lighting switches and lighting.





## 4.2. Location of the pump in relations to noise emission

The comfort of an air heat pump, both for the owner and the close environment, comes down to the noise emissions during its operation. In the case of an air heat pump, the operation of the fans has a significant impact on sound emissions, which directly determines the location of the outdoor unit. Sound emission values are determined outside the building, at a distance of 0.5 m from the center of an open window.

## 4.3. Transportation

It is imperative that the heat pump be transported individually and in an upright position as marked on the package. It is absolutely forbidden to tilt the heat pump more than 45°. The heat pump can be transported using a transport cart or by hand. When transporting, take special care not to damage the unit. Due to the sharp edges present, persons performing transportation are required to use protective gloves. Upon delivery to the installation site, check the model name and serial number of the units. The unit must always be stored in an upright position and be protected from moving. Failure to comply with the above recommendation will result in **loss of warranty**.

## 4.4. Unpacking the product

Before unpacking the device, carry out a visual inspection to check for any damage to the transport packaging. Particular attention should be paid to cracks and bulges in the box. The main activity after unloading the equipment, is to check whether the equipment was not damaged during transport. If a defect is detected, a damage report should be written in the presence of the driver with its confirmation on the document. Any damage noticed during the unpacking of equipment should be immediately reported to the transport company and the service department.

## 4.5. Storage

Unit should be stored in its original packaging, at temperatures between -35°C and 50°C and protected from corrosive weather conditions.

## 4.6. Mechanical installation and mounting

- 1)  When installing a heat pump, it is imperative to use protective equipment and personal protective clothing!
- 2) The heat pump must be installed with vibration-damping rubber dampers on a stable and rigid base that provides adequate strength under the load of the unit.
- 3) In order to ensure proper operation of the heat pump, it should be placed in a place with low dust, providing the least possible corrosive conditions, which ensures proper air circulation and safe opening of the unit. The ambient temperature at the installation site should not exceed +43°C.
- 4) The connection to the power grid should be made by an electrician with current electrical licenses.

### 4.6.1. Setting up the outdoor unit – general guidelines

- 1) In order to ensure adequate airflow to the outdoor unit, it is recommended to install it in an open space.
- 2) The unit must be installed in a way that prevents recirculation of outside air.
- 3) It is not recommended to install the unit near the bedroom or living room due to the generated noise.
- 4) The unit should not be installed in an area with flammable, volatile and corrosive substances.
- 5) The outdoor unit absolutely must have an adequate drainage system.

- 6) It is recommended to install the device with an eave or the use of a special canopy to protect the supply and cooling pipes from rupture caused by precipitation, such as falling snow.
- 7) Due to the run-off condensate, it is not recommended to install the device over the sidewalk or other traffic rows, where a risk of icing can occur.
- 8)  The minimum distances between the device and other partitions must be strictly adhered to. The unit is not suitable for the installation in areas, where a water spray may be used.

### 4.6.1.1. Ground mounting guidelines

- 1) Prepare the foundation in accordance with local conditions:
  - dig a hole in the ground,
  - insert draining pipe for the condensate drainage (10K fi100, for 15K fi160),
  - pile up a layer of coarse gravel.
- 2) Construct two foundation footings.
- 3) Make a gravel base between the foundation footings.
- 4) Level the unit at all points.

Required mounting distances of the pump on the ground:

MINIMAL DISTANCE	VALUE [mm]
A	400
B	600
C	1000
D	1000
E	1000
F	300

Tab. 11. Minimal recommended distance for ground mounting.

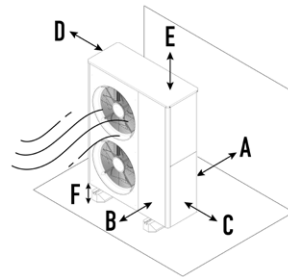
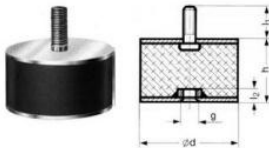

Fig. 20. Layout of the heat pump outdoor unit for ground mounting.

**In order to set the outdoor unit on the ground, use:**

- a) Rubber feet (included), rubber base optional



b) Stand

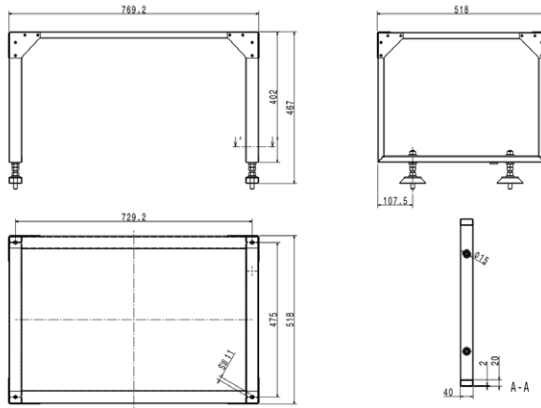

Guidelines for setting the heat pump on the ground are presented in Fig. 21.

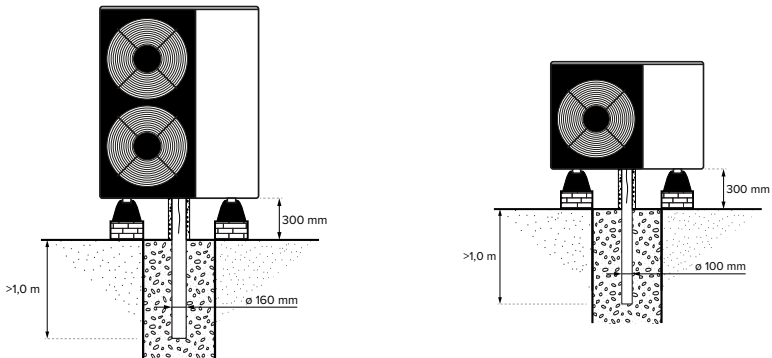
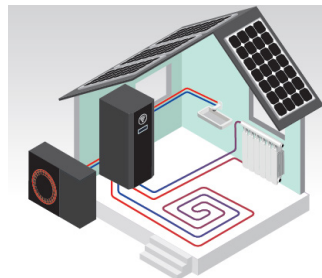

Fig. 21. Guidelines for mounting the heat pump outdoor unit on the ground on rubber feet.

#### 4.6.1.2. Connecting the outdoor unit to the indoor unit

- 1) After mounting the outdoor and indoor units, look for the nearest place in the wall to make a hole. It is recommended that the hole be characterized by the best water resistance.
- 2) After determining such a place in the wall, drill a hole with a diameter of 50-100 mm.
- 3) After making the hole, you need to run two pipes through the wall. Be sure to properly insulate the hole with thermal insulation, such as insulating foam.



### 4.7. Defrost mode

When the pump is operating at temperatures below about 5°C at the set load, frost (icing) may appear on the exchanger. This is because, a large amount of water vapor present in the environment (the so-called humidity) during forced air flow through the exchanger is gradually deposited on the frozen lamella block. The melting of frost is accomplished by the same “compressor” system, or more precisely by changing the direction of refrigerant circulation. The energy required for this is taken from the heating system. The defrosting mode is carried out automatically at strictly defined periods and only when the heating mode is used.

Necessary conditions to start the defrosting process:

- 1) Evaporation temperature is below the value determined by the controller algorithm.
- 2) Ambient temperature is below 7°C.
- 3) Defrost interval exceeds the set value (default 45 minutes).

In JBG<sup>HT</sup> brand heat pumps, the outer surfaces of the evaporator are covered with a hydrophilic coating, which shows excellent water protection properties in high temperatures and salty environments. The solution used consolidates water molecules, which in larger amounts under their own weight flow faster into the drip tray, the end result being the reduced defrosting time.

### 4.8. Electrical installation

#### 4.8.1. Requirements

The device is designed to be powered from the electricity grid:

- 1) Power supply cables and power circuit protection should be selected to meet the condition of automatic power outage.
  - a) 3-phase unit: ~400 [V]/50 [Hz] 3L + N + PE
- 2) Power cables should be appropriately selected due to the length of the power lines and the characteristics of their routing:
  - a) 3-phase min. 5 x 4 mm<sup>2</sup>
    - Protection, overcurrent circuit breakers for the unit:
      - a) ZHHS-01-10K-R290-V5: 10 A characteristics C, 3-phase, 3L + N
      - b) ZHHS-01-15K-R290-V5: 16 A characteristics C, 3-phase, 3L + N
- 3) It is required to use residual current protection in accordance with applicable standards
- 4) In a 3-phase pump, connect the electric heater to the least loaded circuit.
- 5) The device is supplied with electrical voltage hazardous to life.
- 6) All work related to the repair and service of the device must be performed by personnel with the appropriate authorizations.
- 7) Before starting the device, check the device for damage, especially cables and electrical apparatuses.
- 8) The detection of any damage to the equipment will result in the prohibition of its commissioning and operation.
- 9) When making an electrical connection, the technical conditions for connection to the power grid shall be observed.
- 10) The electrical connection ratings must match those on the equipment nameplate.
- 11) The electrical cables and protection used, as well as the execution of the electrical connection, must meet the requirements of standards and local regulations.



- 12) Electrical cables must be suitable for outdoor use in suitable conditions.
- 13) Improper selection of power cable may lead to damage to the unit and may be a danger to the environment.
- 14) An improperly made electrical connection can cause electrocution and, during operation, cause damage to the unit, electrical system or lead to significant property damage.
- 15) When connecting the device to the power grid, make sure that the electrical voltage of the connection is turned off and protected against uncontrolled switching on.
- 16) Properly prepare and plan the installation of the unit and the electrical system.
- 17) Connect the electrical connection to the terminals of the unit in accordance with the electrical diagram of the unit.
- 18) After connecting the device to the power grid, take appropriate electrical measurements and draw up a measurement protocol.
- 19) Control wires and sensors should be routed at a distance of min. 100 mm from the power wires.
- 20) Modbus network cables may not be extended.
- 21) Ensure that the power phases of the compressor are connected in the correct order. Otherwise, the compressor may be damaged.
- 22) It is forbidden for the customer to alter the electrical circuit.
- 23) Ability to work with an alternative source (potential-free contact 13/14 on the contactor). In previous versions, use a relay with NO5 contact (alternative source).
- 24) Contact temperature wire B4 and B5 can be extended according to Table 12.

Lp./Cable		2 x 0,35		2 x 0,75		Default cable
	<b>Temp.</b>	<b>Resistivity 30 m</b>	<b>Temp Read</b>	<b>Resistivity 30 m</b>	<b>Temp Read</b>	<b>Resistivity 3 m</b>
1.	20,0	12,07	20,0	12,1	20,0	12,09
2.	30,0	8,30	30,0	8,31	30,0	8,32
3.	40,0	5,83	40,1	5,837	40,1	5,83
4.	30,0	8,33	30,0	8,33	30,0	8,33

*Tab. 12. Extensions of probe cables.*

Types of cables	Phase / Cable cross section
<b>Power supply for electric heater:</b>	
Cable	L1 x 2,5 mm <sup>2</sup>
Cable	N x 2,5 mm <sup>2</sup>
Cable	PE <sub>1</sub> x 2,5 mm <sup>2</sup>
Circulation pump power supply	3 x 1 mm <sup>2</sup>
PWM control	2 x 0,25 mm <sup>2</sup>
Flowmeter	2 x 0,25 mm <sup>2</sup>
NTC probe (3s)	2 x 0,25 mm <sup>2</sup>
Communication cable - shielded twisted pair	Min. 2 x 0,34 mm <sup>2</sup>
PGDe display power cable	6 x 0,1 mm <sup>2</sup>
<b>Power cables:</b>	
3-phase	5 x 4 mm <sup>2</sup>

Tab. 13. Types, phase and cross section of cables.

25 ) Connecting the outdoor unit:

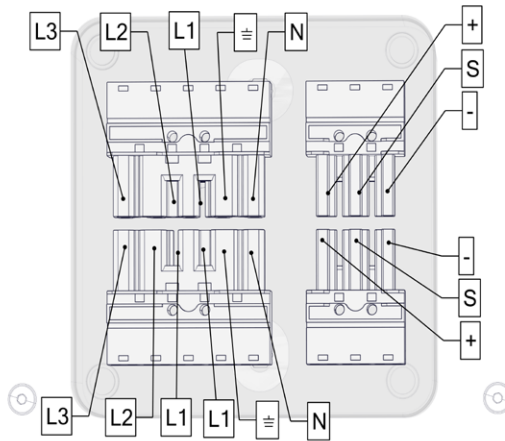

Fig. 22. Wiring diagram of the outdoor unit.



4.8.2. Diagrams of the electrical system

4.8.2.1. Diagram of the 3-phase electrical system in the outdoor unit

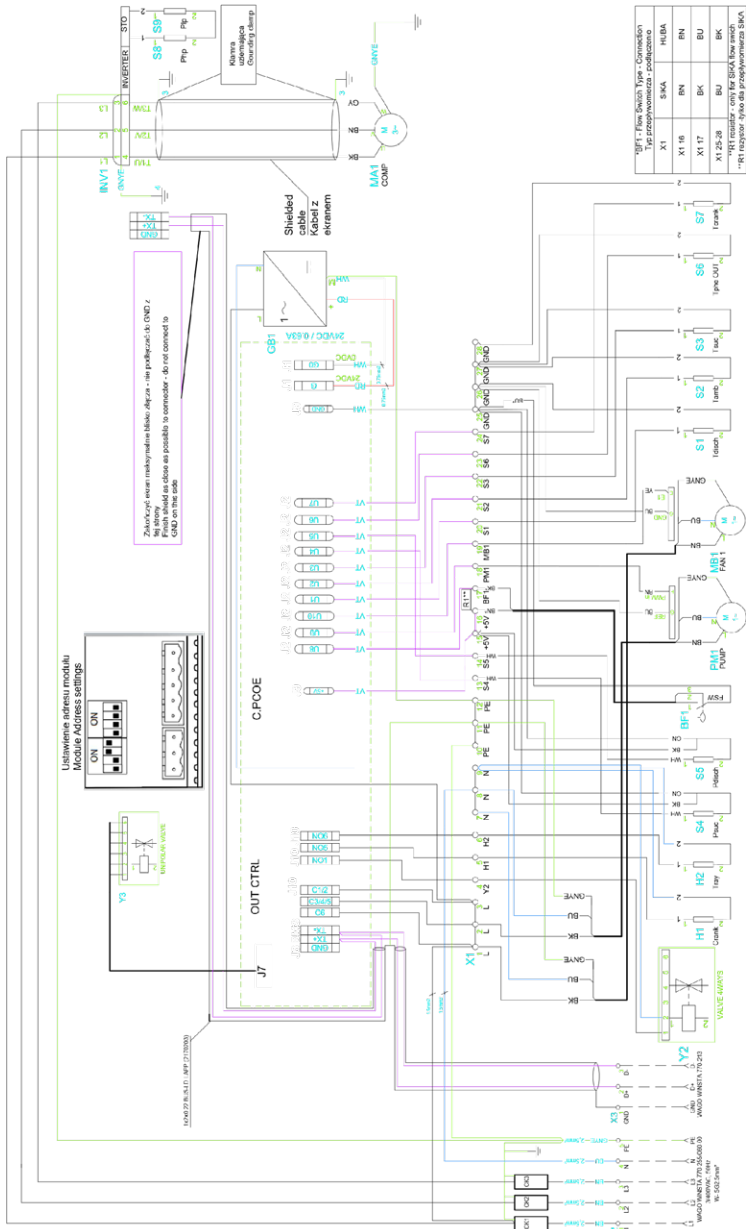
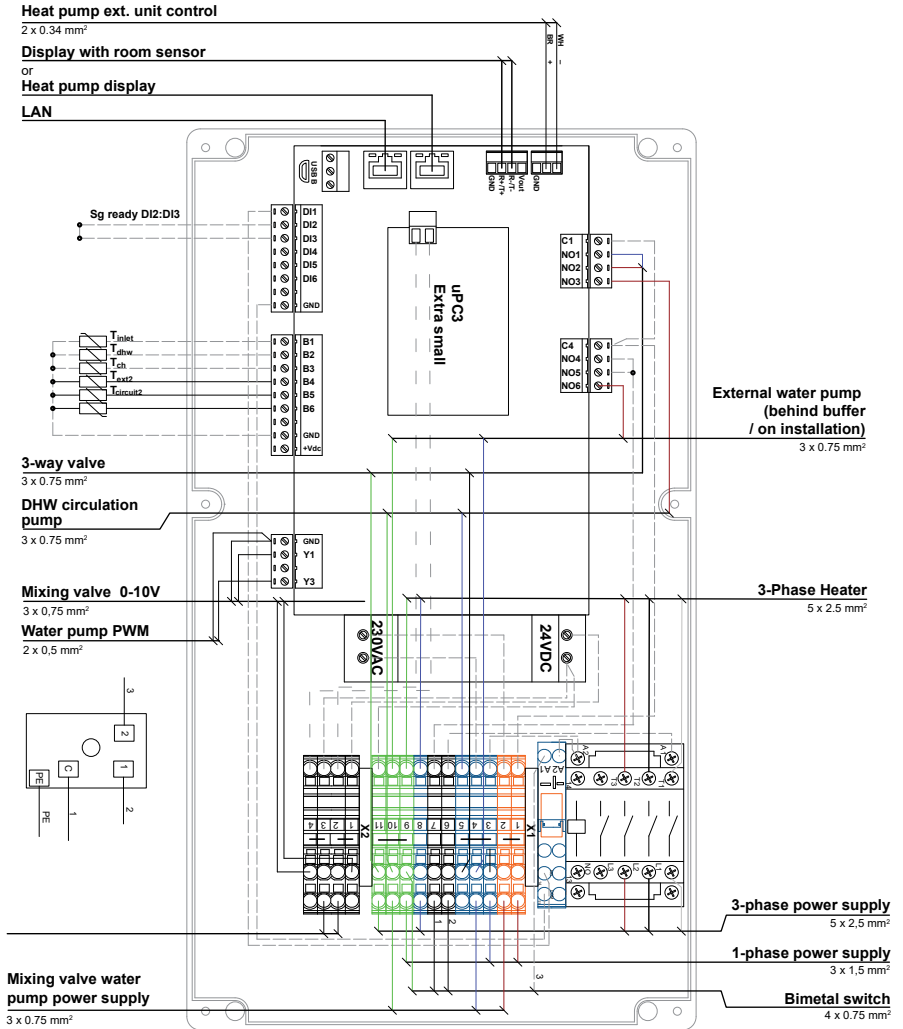

Fig. 23. Diagram of electrical system of the outdoor unit





**4.8.2.3. Installation diagram of electrical connections**



- |   |                            |
|---|----------------------------|
| B1 Return to heat pump temperature sensor | NO1 3-way valve (DHW flow) |
| B2 DHW temperature sensor (in tank)       | NO2 3 way valve (CH flow)  |
| B3 Plant temperature sensor (in buffer)   | NO3 DHW circulating pump   |
| B4 External temperature sensor            | NO5 Electric Heater        |

**ELECTRIC WIRING DIAGRAM**

Fig. 25. Electrical and installation diagram of wiring connections of the heat pump power and control system.

### 4.8.2.4. Heater power selection

- 1) When installing a Hydrobox or Hydrotower product, select the heater power for auxiliary purposes. Default power is set to 3 x 3kW. Disconnect one or two heating circuits, make sure to secure the contact.

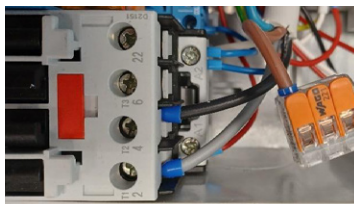

- 2) Thermal protection of the heater in the manual version protects the water from boiling. Shutdown at 95 degrees.
- 3) Automatic heater thermal protection protects the water from boiling (factory setting 70 degrees).

## 4.9. Hydraulic system

### 4.9.1. Requirements

- 1) Pipes used in the heating circuit must be thermally insulated. The insulation must be resistant to UV as well as high and low air temperatures.
- 2) Connect the water return and supply of the heat pump as presented in Fig 26.

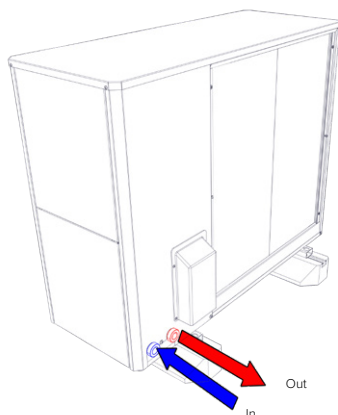

Fig. 26. Heat pump supply and return connections.

- 3) Before connecting the heating system to the indoor unit (hydrobox/hydrotower) of the heat pump, it should be flushed thoroughly to remove possible residues in the pipes.
- 4) Install a magnetic dirt filter on the pipeline at the point where the heating circuit returns to the heat pump. If the heat pump is installed at the highest point of the heating circuit then additional vent valves should be installed at these locations. After venting the system, turn off the vents in the system and in the heat pump.



- 5) Drainage of condensed water must be provided by a pipe with a minimum diameter of 100 mm for 10K and 160 mm for 15K. It is permissible to use a drain inserted vertically into the ground for a minimum of 90 cm, if the ground is permeable to water.
- 6) Pipe dimensions:

Dimensions of CH piping

Heat pump	Copper pipes	Steel pipes	Polypropylene pipes	Max. flow	Min. flow
ZHHS-01-10K-R290-V5	28 x 1	32 (5/4")	32 x 4,4	1,68 m <sup>3</sup> /h	0,54 m <sup>3</sup> /h
ZHHS-01-15K-R290-V5	35 x 1,5	32 (5/4")	40 x 5,5	2,1 m <sup>3</sup> /h	0,72 m <sup>3</sup> /h

Tab. 14. CH pipe dimensions

- 8) A CH buffer is recommended in thermally upgraded facilities.
- 9) Recommended methods against freezing:
  - A. Use propylene antifreeze throughout the system to -7°C. Increase the flow rate by 10% on the circulation pump. Glycol concentration must not exceed 35%.
  - B. Use of a system with manual removal of water from the exchanger. Two drain valves in the form of shut-off valves should be installed in the building to remove water from the exchanger by gravity. Additional two shut-offs to prevent the removal of water from the rest of the system.

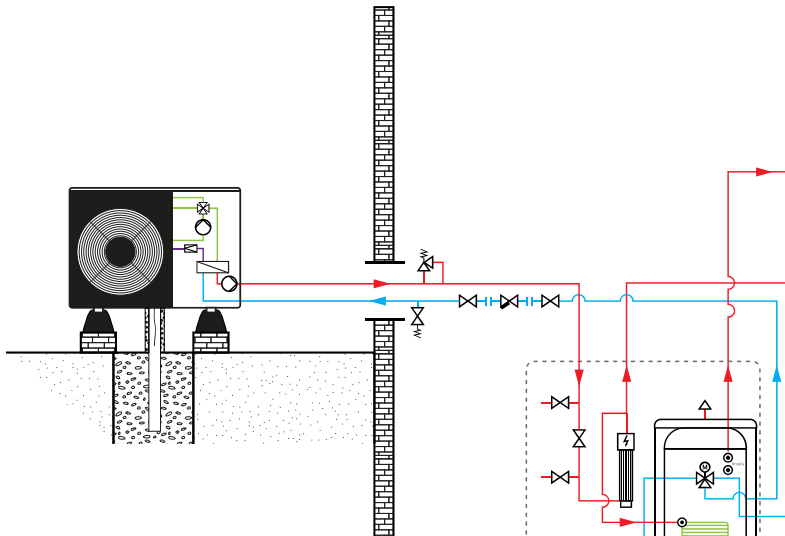

Fig. 27. Antifreeze protection.



**4.9.2.2. Diagram of hydraulic system with series buffer (underfloor heating)**

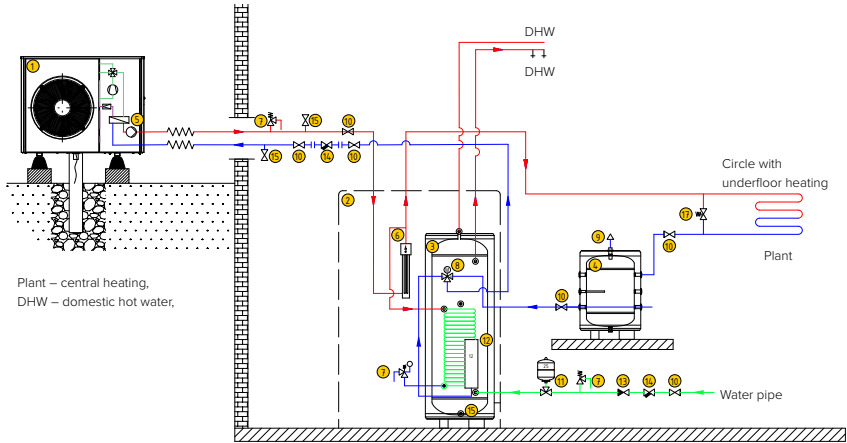

Fig. 29. Diagram of hydraulic system with series buffer (underfloor heating)

**4.9.2.3. Diagram of hydraulic system without a buffer (underfloor heating)**

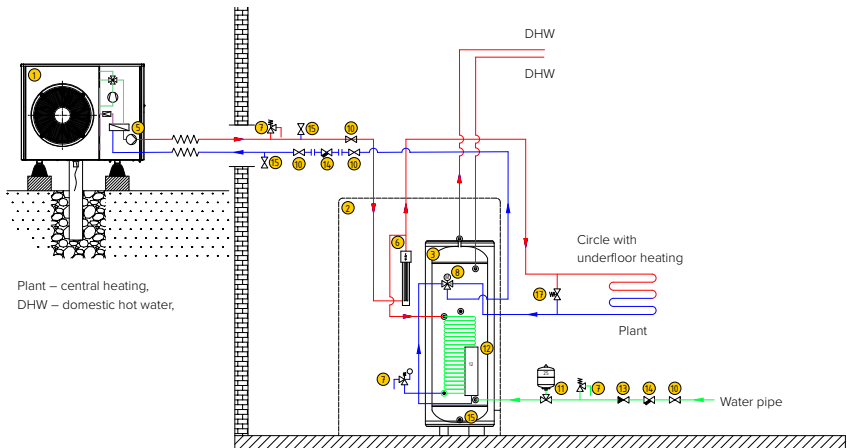

Fig. 30. Diagram of hydraulic system without a buffer (underfloor heating)



**4.9.2.6. Detailed diagram of Hydrobox module**

1	Diaphragm vessel
2	Electric heater
3	Safety thermic
4	Automatic vent
5	3-way valve
6	Manometer – safety group
7	Power supply from PC
8	CH power supply
9	DHW power supply
10	CH return
11	HP return
12	DHW return
HP	Heat pump
DHW	Domestic Hot Water
CH	Central heating

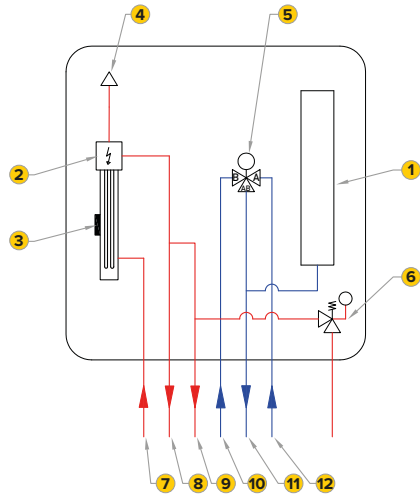

Fig. 33. Hydrobox hydraulic diagram

**4.9.2.7. Detailed diagram of Hydrotower module**

1	200L DHW Tank
2	Diaphragm vessel
3	Electric heater
4	Safety thermic
5	3-way valve
6	Manometer – safety group
7	DHW drain valve
8	Anode
9	DHW temperature sensor
10	Power supply from PC
11	CH power supply
12	CH return
13	HP return
14	Domestic Hot Water
15	DHW circulation
16	Cold water supply mains
HP	Heat pump
DHW	Domestic Hot Water
CH	Central heating

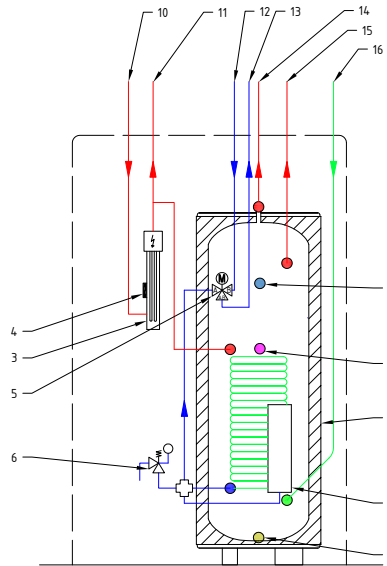
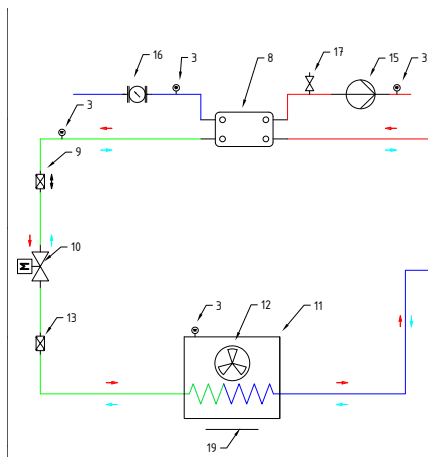

Fig. 34. Hydrotower hydraulic diagram

## 4.9.3. Diagram of the refrigeration system



- 1 Scroll compressor
- 2 Inverter
- 3 Temperature sensor
- 4 Miniature pressure switch
- 5 HP pressure transmitter
- 6 Maintenance valve
- 7 4-way valve with coil
- 8 Condenser
- 9 Dehydration filter
- 10 EEV valve
- 11 Evaporator
- 12 Fan
- 13 Mesh filter
- 14 LP pressure transmitter
- 15 Circulation pump
- 16 Flow sensor
- 17 Automatic vent
- 18 Crankcase band heater
- 19 Tray drip heater

Fig. 35. Refrigeration system diagram

## 4.9.4. Water supply system

Before filling or any subsequent refilling of the system, make sure to check the quality of the water in the heating system:

- Visually check the water for precipitation of other materials. If this occurs, the user is required to clean the system.
- Use only demineralized heating water or water that complies with the VDI 2035 standard. Failure to do so may result in a decrease in the efficiency of the device and even damage to its components.

Desliming of the system is not included in the installation and commissioning of the heat pump.

- Check with a magnetic rod whether magnetite (iron oxide) is present in the water. If found, treat the water accordingly.

In the case of an existing installation, clean the system and install a magnetic filter.

- Check the pH value of the water at a temperature of 25°C.

It is generally accepted that water should be treated if the values in Table 16 are not met.

Heating power	Water hardness in relation to the volume of the installation					
	≤ 20 $\frac{l}{kW}$		20 - 50 $\frac{l}{kW}$		> 50 $\frac{l}{kW}$	
kW	°dH	mol/m <sup>3</sup>	°dH	mol/m <sup>3</sup>	°dH	mol/m <sup>3</sup>
< 50	< 16,8	< 3	11,2	2	0,11	0,02

Tab. 16. Recommended water hardness values

Improper additives can cause the risk of material damage and harmful physical changes in parts. This can be especially true for seals of all kinds. For this reason, antifreeze, corrosion inhibitors and sealants should not be used. The technical parameters of the installation water should be checked at the annual technical inspection of the heat pump and corrected as necessary to the required values.





## 4.9.5. Filling up and venting the system

Fill the system with heating water. Slowly increase the filling pressure until the desired working pressure is reached. The working pressure should be between 1.5 and 2 bar. For filling, use a suitable cart with a tank and pump, which allows you to properly vent the installation. During filling, control the vent valves. When venting, check the pressure in the system. If the pressure drops, top up the water system. After filling and venting, activate the heating circuit pump on the controller.

## 4.9.6. Installing the DHW sensor

An important step that goes into the first start-up procedure is to check the correctness of operation of the heat pump sensors. In a configuration with a DHW tank, one such sensor is the probe that measures the temperature of domestic hot water. It is important to install this sensor correctly. It should be placed halfway up the tank, inserting it inside the tank through the designated entrance. The location of the sensor is presented in Figure 36.

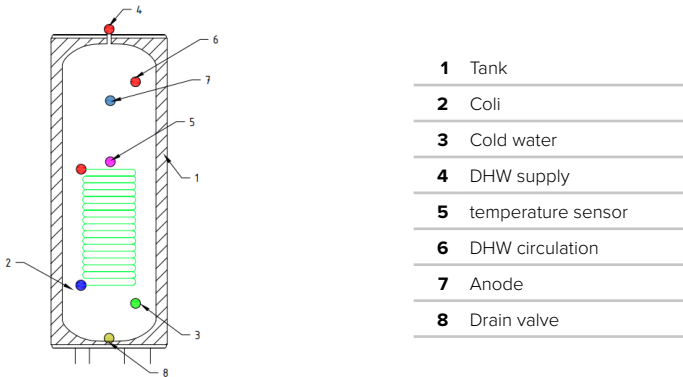

Fig. 36. Location of the DHW sensor

## 4.9.7. Initial startup

The first start-up of the installation is performed by an authorized Installer. During the first start-up a **PROTOCOL OF ACCEPTANCE / START-UP OF HEAT PUMP** is drawn up.

### Scope of services for the first start-up performed by an authorized Installer:

- 1) Checking fan operation.
- 2) Checking the quality and tightness of the water supply system.
- 3) Checking the supply voltage of the unit.
- 4) Ensure that the unit is properly grounded.
- 5) Checking the correctness of operation of electrical safety devices.
- 6) Checking the quality of electrical connections.
- 7) Check for positive pressures in the system to verify that the system has been filled with refrigerant.
- 8) Check water and air temperatures to verify proper operation of heat pump sensors.
- 9) Turning on the heat pump.
- 10) Control of the obtained operating parameters of the heat pump.
- 11) Instruct the user on the basic operation of the heat pump.

The heat pump first startup service does not include installation activities such as:

- 1) Installation of heat pump units (routing of electrical and hydraulic cables)
- 2) Installation of accessories and electrical equipment (circulating pump sensors, electrical safety devices)
- 3) Filling and venting the system.

## 4.10. Installing the Internet module

### 4.10.1. WiFi connection at the User's site (Wireless network as an output to the Internet).

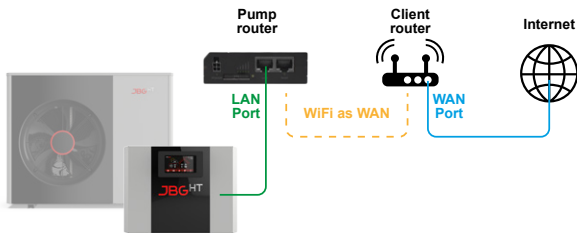

### 4.10.2. Cable connection at the User's site (Cable network as an output to the Internet).

Cable configuration requires no further setup.

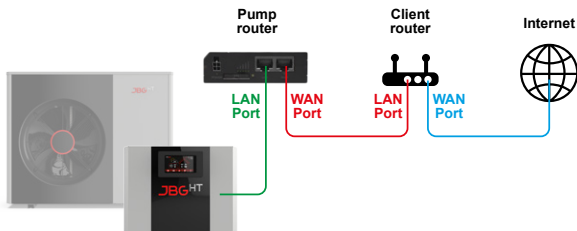

### 4.10.3. Cable connection at the User's site (to check Internet access).

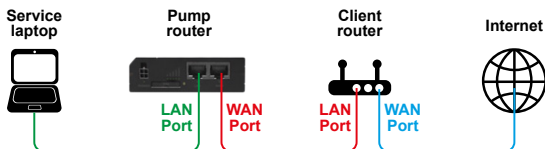

#### 4.10.4. WiFi Configuration

After **connecting the laptop to the LAN port on Teltonika**, we enter the device through the address we see in the address bar (**172.28.29.254**). We log in with the following credentials to the Montera account:

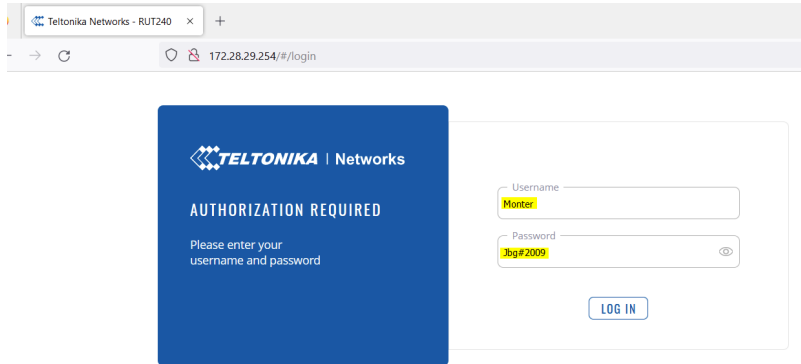

- 1) In order to connect the router to the client's wireless network, we select **NETWORK** then **Wireless**

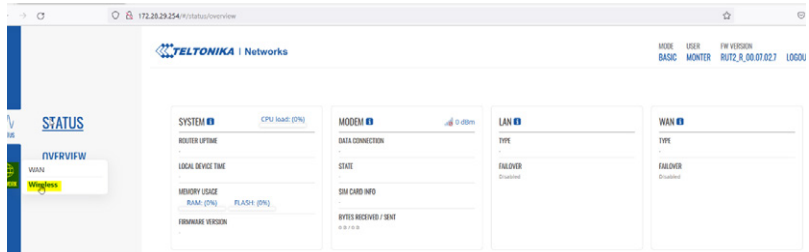

- 2) Scan the network by selecting **SCAN**.



- 3) From the list of available networks (there may be many in range), select the client's network by choosing **JOIN NETWORK**. If there is none, it is possible that none are in range or the antenna has not been screwed in.

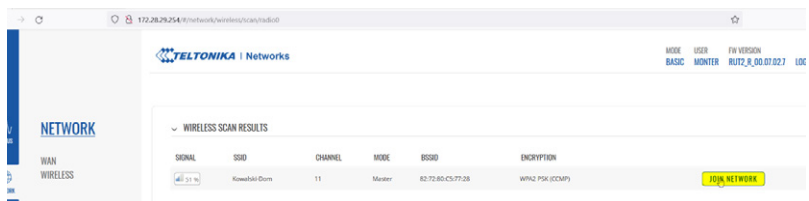

- 4) Enter the User's password in the field **WPA Passphrase** and **Klient** in the field below and confirm by selecting **SUBMIT**.

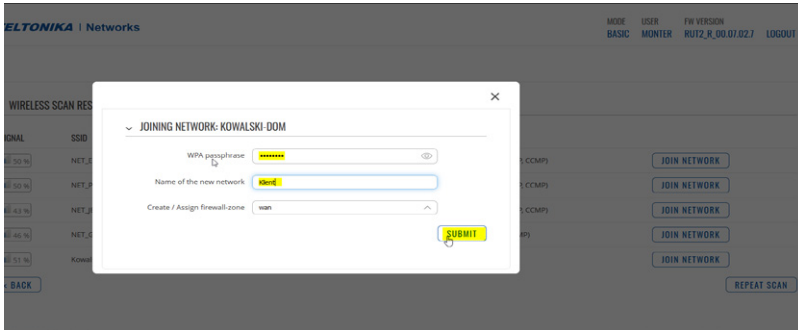

- 5) Confirm previous steps by selecting **SAVE&APPLY**

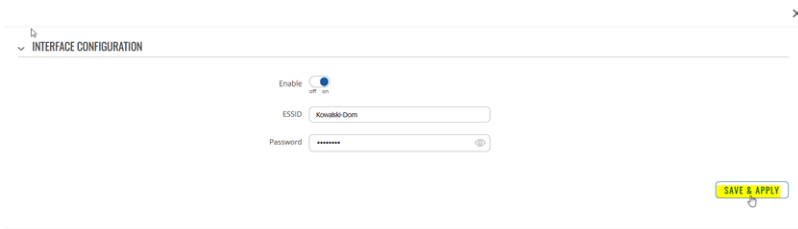

- 6) After the page refreshes itself, the wireless network status screen will appear. We can see the correct **Running** status and the percentage of **signal quality (here 72%)**. If the status is different, it may mean that the User's network coverage is too poor.

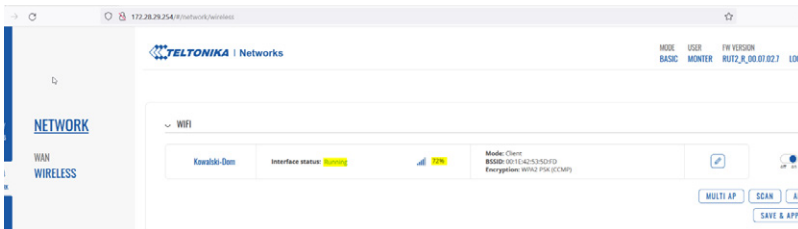

- 7) After a few minutes, check the availability of the Internet by going to the website.

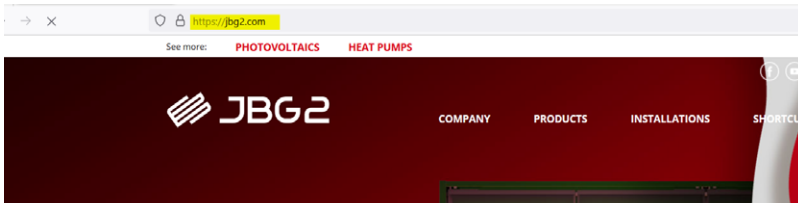

## 5. STARTING UP THE HEAT PUMP

### 5.1. Controller Main Screen

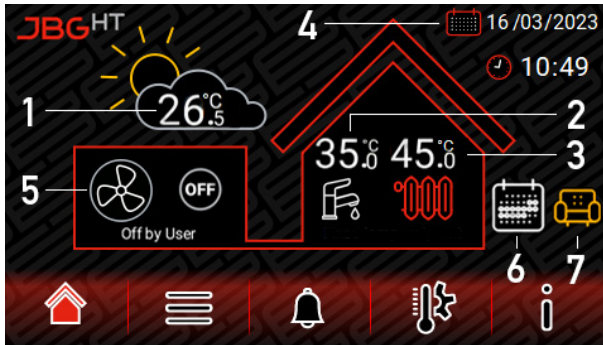

Visualization of pump operation:



heating mode



stop by alarm



fan operation



pump off



defrost



shutdown mode



standby mode

1 – outdoor temperature

4 – current date and time

6 – active calendar

2 – DHW temperature

5 – heat pump status (mode)

7 – installation operation mode

3 – CH temperature

### 5.2. Menu Icons

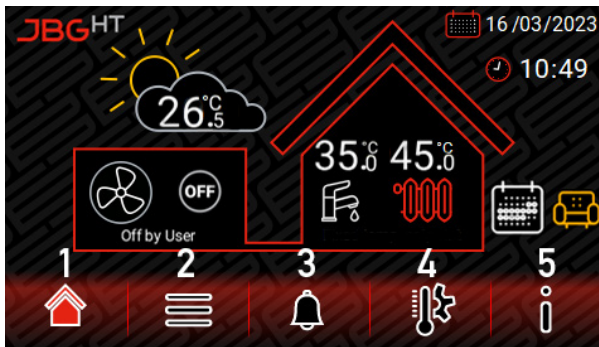

1 – home screen

3 – alarm

5 – Info (About)

2 – options and settings

4 – CH i DHW temperature setting



if there is a number next to the icon it means the number of active alarms

## 5.3. Turning on and off

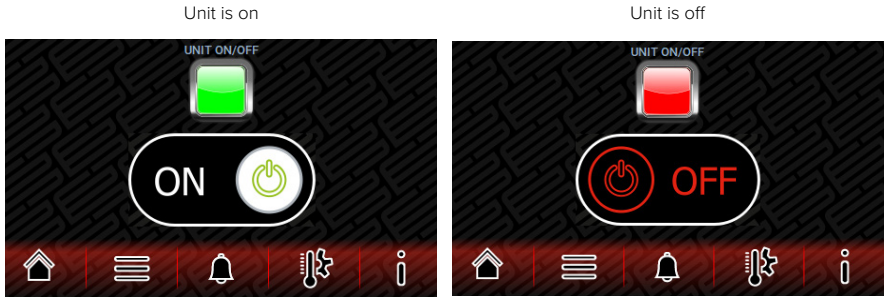

## 5.4. CH and DHW temperature settings

CH operation point  
Measured value  
(for room control)  
Operating point Room  
Measured value



DHW operation point  
Measured value

 Settings should be made for the various available modes of operation.

## 5.5. Logging in

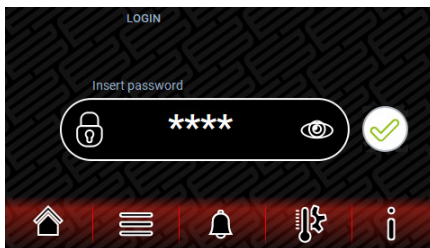

Access to the "Options and Settings"  
is password-protected.

Default passwords:

- User: 1234
- Installer: \*\*\*\*



5.6. Options and settings



- Calendar CWU – DHW schedule
- Calendar CH – schedule plant
- Device – advanced settings
- Parameter – Heater settings
- Settings – Date/time and other
- Service – service technician settings

5.6.1. CH/DHW Calendar

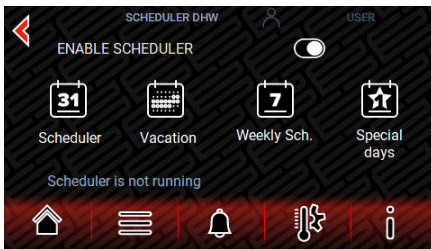

Calendar activation

5.6.2. Calendar

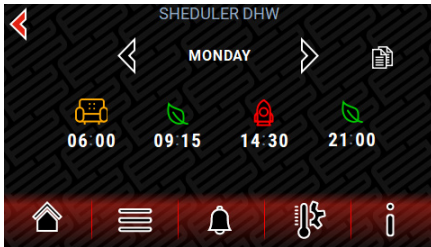

Operation modes of the installation during schedule activity:

- Inactive
- Comfort
- Off
- Boost
- Economic

5.6.3. Setting a schedule

The working day of the unit can be divided into 4 periods, for which you need to set a time interval and assign an operating mode.



The value is changed by operating with the up and down arrows.

Confirm and cancel .

The icon can be used to copy the settings parameters of one day to the next.

## 5.6.4. Vacation Periods



Setting vacation periods is implemented by selecting a date range. Within this range, the pump will operate in the selected mode, regardless of the settings of the standard calendar.

## 5.6.5. Week view

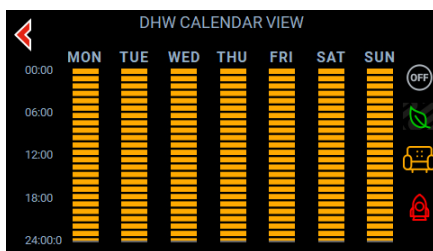

The weekly calendar is presented in the form of colored bars that show the mode set.

Activities are according to the colors of the mode icons on the right. Clicking on the bar of each day takes you to the day settings.

## 5.6.6. Special days

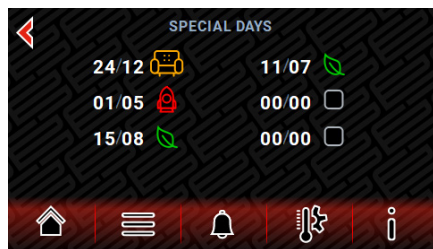

It is possible to set up to 6 special days on which the heat pump will operate in the selected mode independently of the standard operating calendar. We can freely choose the mode of operation on a given day. Clicking on the date will bring up the setting window.

## 5.6.7. Date and time

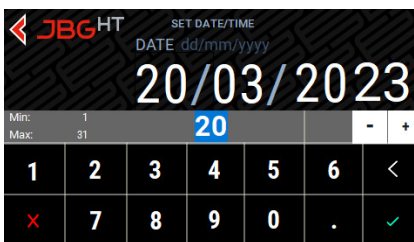



## 5.6.8. Manufacturer

This option is for the Heat Pump Manufacturer only.

## 5.6.9. Service

This option is for the Heat Pump Service Technician only.

## 5.7. Quick Guide

Quick Guide is a procedure to go through during the first startup that allows you to set the basic parameters of heat pump operation. At any time, the user will be able to return to this procedure to change the settings he or she previously selected. To start the Quick Guide, go to Settings in the Options and Settings Menu, and there select the “Quick Setup” field.

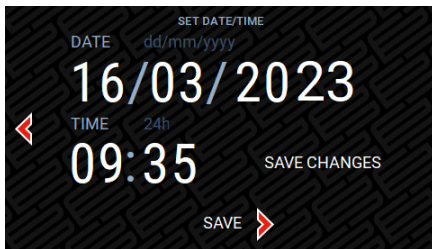
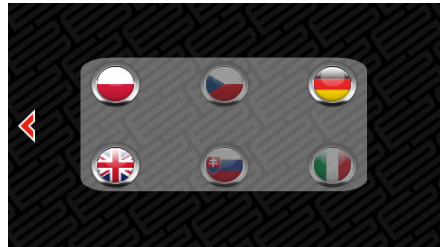
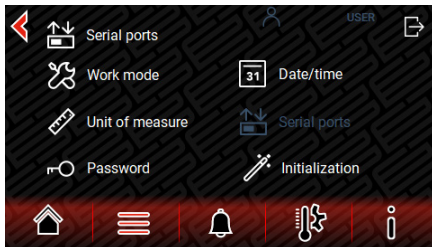

Next, set the current date and time.

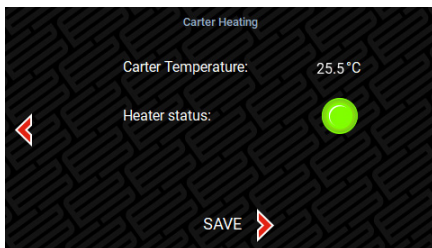

The next step is to heat up the crankcase. Running the heat pump without a heated crankcase can result in errors and is dangerous for the compressor.



Once the compressor crankcase is warmed up, select the mode in which the heat pump will operate. There are three modes to choose from:

- PLANT (Central Heating)
- DHW (Domestic Hot Water)
- PLANT + DHW (Central Heating + Domestic Hot Water)

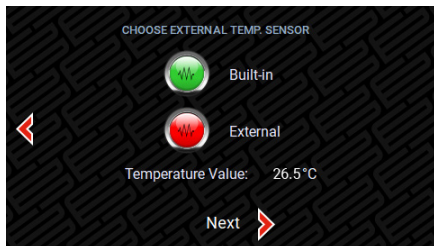

The next step is to select the temperature sensor that will be the master sensor in the control algorithms.



The purpose of the probe, which can be connected to input B6, is then selected. If you select the temperature of circuit 3, it will be possible to configure a third heating circuit at a later stage. If you do not have a display with an integrated temperature probe, the room temperature measurement function can be set for probe B6.

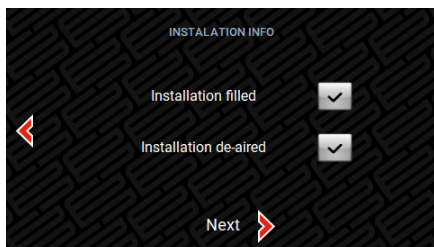

Before starting the heat pump, the system must be filled and vented. If these actions are not performed, the controller will not allow you to proceed to the next step until you complete these steps.

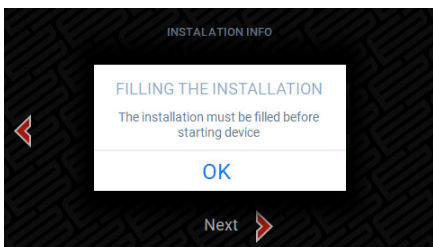
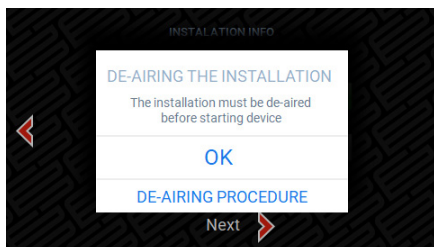

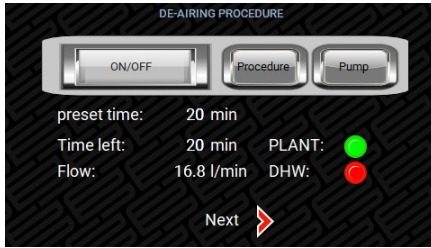

If venting has not been performed, select “Venting procedure”. Then, after selecting the “START” field, the circulation pump will run in cycles:

- 5 min CH mode 100% power
- 5 min CH mode 0% power
- 5 min DHW mode 100% power
- 5 min DHW mode 0% power

The cycles work in a loop.

The next step is to check whether the circulation pump is working properly. To do this, you force the maximum flow rate and observe the reading from the flow meter. If there is no flow, you cannot proceed further. If there is no flow, you should:

- check that the relevant valves are open
- check the correct installation of the flow meter
- check that the pressure gauge (manometer) shows the pressure in the system
- check that the green light on the circulation pump is on
- check the correctness of the electrical connection of the circulation pump and the flow meter

The minimum medium flow rate should be set at 9 l/min for the 10K pump and 12 l/min for the 15K pump, and the maximum flow rate should not exceed 28 l/min for the 10K pump and 35 l/min for the 15K pump. It is very important to set after which sensor the compressor regulates. For users with a buffer, it is recommended to set the regulation after the temperature of the water in the buffer. Otherwise, the Inlet/Outlet type of regulation should be selected, along with specifying that the start and ongoing regulation are to be after Outlet. The recommended mode of operation is “Always On.” When the heat pump is switched to hot water heating mode, you may find that the maximum flow rate will be different from that of central heating operation. Set the appropriate minimum and maximum values for DHW mode as well.

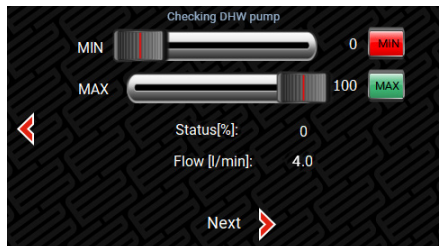
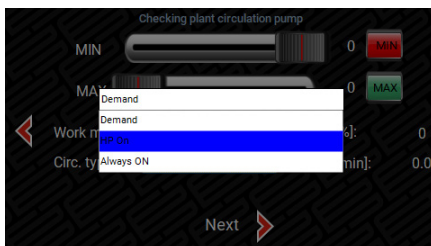
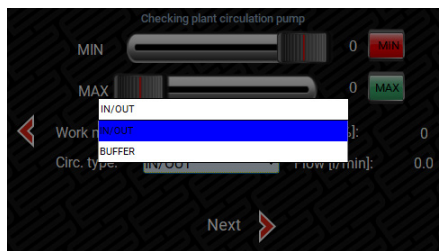
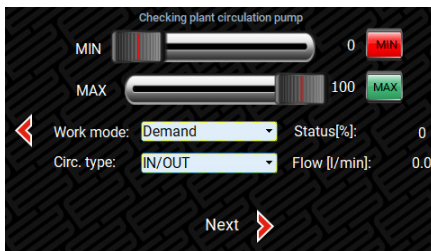

## INSTRUCTION MANUAL – HEAT PUMP

If the user has a DHW circulation pump, its operation algorithm should be set. The following modes are available:

- **OFF** – always off
- **ON** – always on
- **ECO** – Ecological mode operating cyclically according to the setting of the following parameters  
ECO switch-on time: the period of operation in ECO mode  
ECO switch-off time: standby period in ECO mode
- **CALENDAR** – always on when DHW heating is active in the calendar
- **ECO CALENDAR** – operation as in ECO mode when DHW heating is active in the calendar

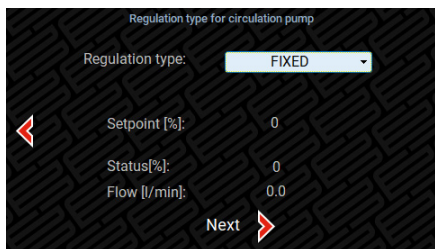
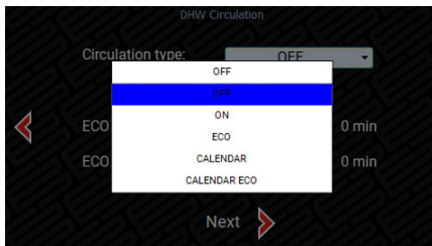
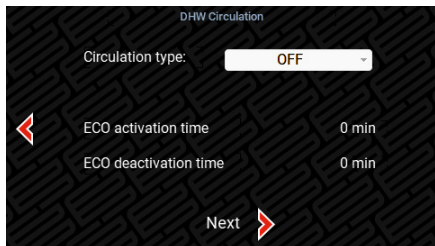

In addition, the control mode is selected. "Delta" ensures that a temperature difference of 5K is maintained between the inlet and outlet water temperatures of the exchanger, while "Fixed" gives you the option to set a constant flow rate.

Before starting the heat pump, it is necessary to ensure that the water temperature in the circuit is at a minimum of 18 degrees Celsius. For this purpose, a pre-heating procedure has been created, which allows you to heat the water in the CH and DHW circuit to the set temperature with an electric heater.

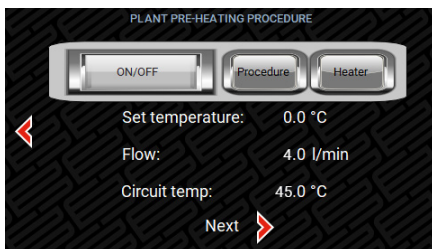
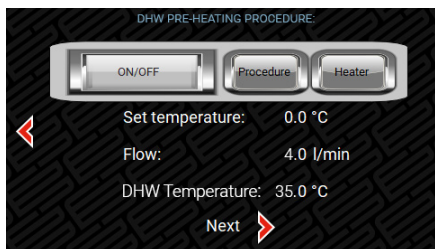

It is necessary to set the ambient temperature below which, if there is a demand, the auxiliary heat source (electric heater by default) will start. Below the booster temperature, the heater starts up for a certain period of time if the heat pump has not reached the set temperature, and in addition, the return temperature has not risen for a long time. Below the bivalent source switch-on temperature, the heater starts permanently until the demand is met.



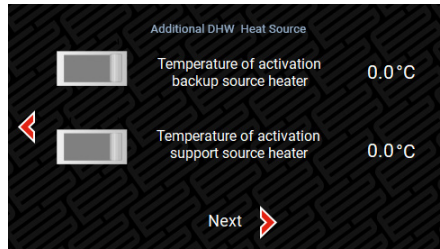
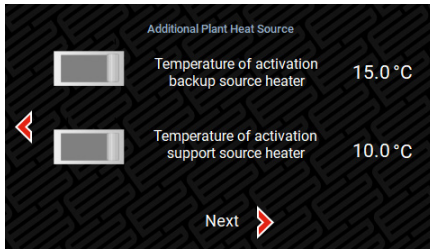

Next, you need to set the heat pump control method. There are two modes: heating curve and temperature setting. When selecting a heating curve, intelligent heating curve adaptation can additionally be activated using room control by means of a room temperature sensor.



In the “heating curve” mode, the algorithm works in such a way that four outdoor temperature points and their corresponding supply temperatures are set. This means that at a given ambient temperature, the compressor will adjust its speed to achieve the outlet temperature setpoint at that point. For ambient temperatures between the designated points, the setpoint is calculated by interpolation. The exceptions are the limit points X1 and X4, beyond which the setpoint no longer changes. The heating curve is baseline. For Pre-Comfort Comfort and Economy modes, the heating curve offset value is set, i.e. by how many kelvins for these modes the heat pump is to have a higher/lower setpoint. When room control is activated, the room temperature setpoint is again set for Economy, Comfort and Pre-Comfort modes. The heating curve will automatically correct itself to reach the room temperature setpoint.

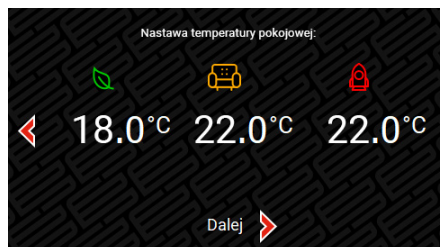
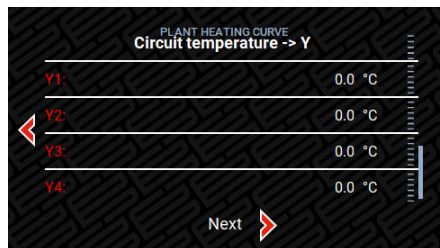
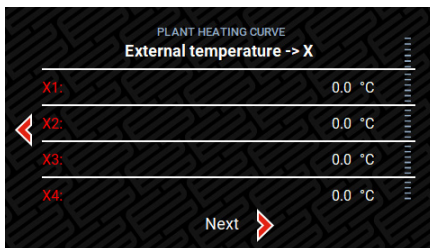

For the “temperature setpoint” mode, the CH temperature setpoints for Economy, Comfort and Pre-Comfort modes are set directly. Then, for both the “heating curve” and “temperature setpoint” modes, three fixed hot water temperature setpoints are set.

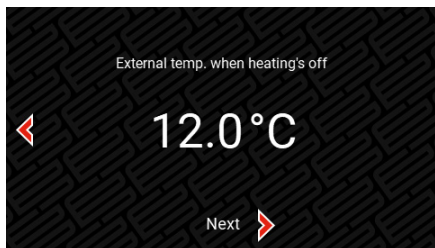
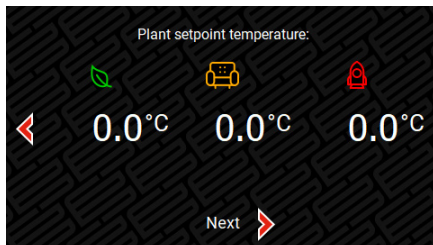
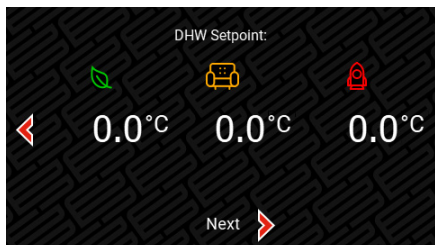

It is also necessary to set a positive limit temperature for which the heat pump will be turned on. The possibility of starting the heat pump is controlled by a relay with a hysteresis of 1°C. For example, selecting a limit temperature of 12°C, after reading 11.5°C from the outside temperature sensor, the heat pump will turn off, while start-up will be possible when the temperature drops below 12.5°C. In order for the algorithm to work, the switching conditions must be met for a certain period of time.

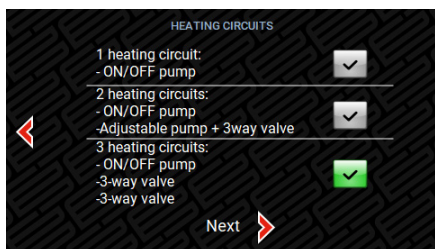

In the next window, you select how many heating circuits you have. In order to be able to select 3 heating circuits in the “B6 probe function” window, you must select the “Temperature circuit 3” option. Depending on your choice, the appropriate windows will be displayed later.

The next step is to configure the CH buffer pump (if any). This is the circulating pump after the buffer that unloads the buffer. You can set this pump to be off all the time, on all the time, or only when the heat pump is on, or make adjustments based on the temperature in the buffer. Then set the temperature you want the buffer to reach, as well as the hysteresis. If the temperature of the water in the buffer exceeds the set point, then the pump will start and unload the buffer. The process will continue until the temperature drops below the setpoint - hysteresis value.



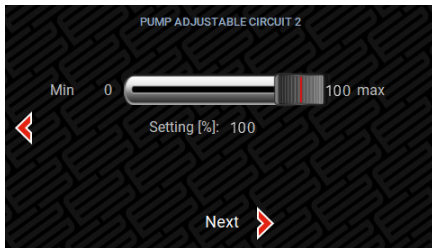
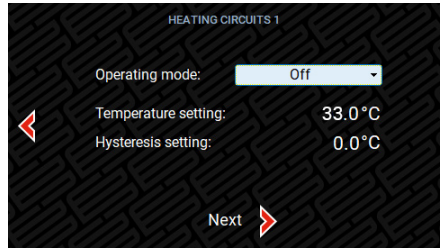
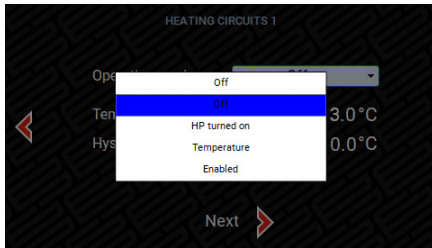

If two heating circuits have been selected, then in the next window the fixed working value of the second heating circuit pump expressed in percentage is set.

Next, the parameters for the operation of the mixing valve of the second heating circuit are set. You can set a fixed percentage of valve opening or automatic operation. In addition, it is selected whether the desired temperature of the second heating circuit is to be fixed (then it should be entered) or is to be regulated according to the heating curve. If the mode with three heating circuits is selected, then instead of the regulated pump of the second circuit, the control output is used for another mixing valve and analogous variables are set for the valve of the third circuit as for the valve of the second circuit.

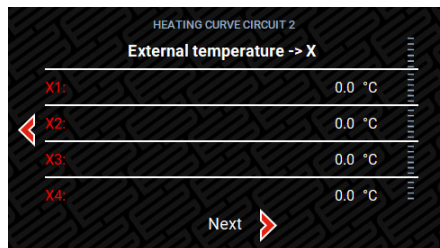
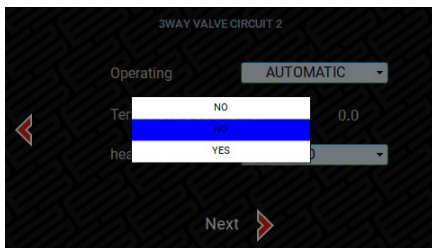
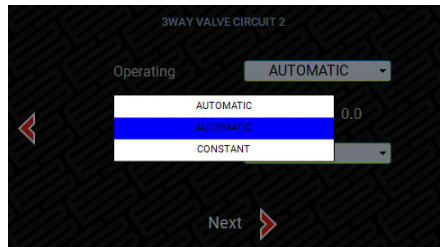
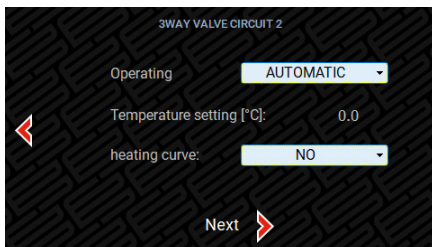

After setting the parameters, the floor dehumidification option can be started before the first startup. It consists of heating for 30 days to a set temperature imposed by the algorithm. Each day the setting is changed. The mode can also be started from a day other than the first day.

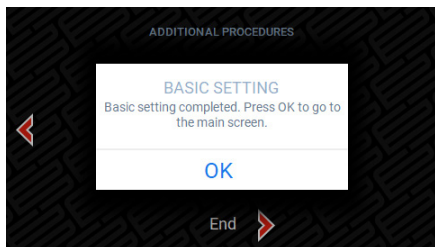
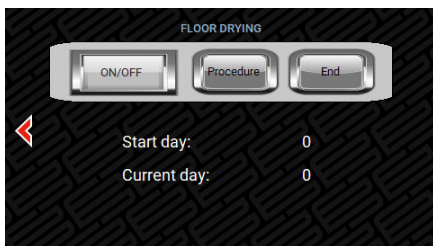
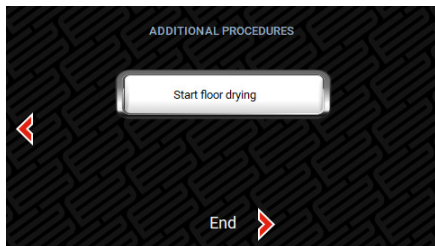

After completing the whole initiation procedure, you can start the heat pump.

## 6. SETTINGS AVAILABLE TO THE SERVICE TECHNICIAN

### 6.1. Weather control

It is possible to adjust the CH set point using the so-called heating curve. This involves setting four points (X,Y) where you define the water temperature set point for a given ambient temperature. Between these points, the temperature setpoint is interpolated using a linear function.

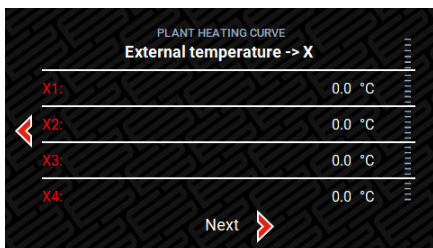
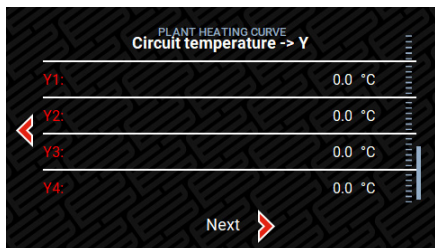

### 6.2. Mixer heating curve

When a heat pump user has an installation containing both radiators and underfloor heating, water of a different temperature is needed to feed the radiators and of a different (lower) temperature to feed the underfloor system. For this purpose, an algorithm for an additional heating curve is implanted, which determines the supply temperature of the floor heating system depending on the ambient temperature. In this case, the CH heating curve is the radiator supply temperature. Maintaining the correct temperature of the underfloor supply is ensured by the mixing system (accessory), which mixes the outlet water from the exchanger with a higher temperature with the return water from the underfloor, thus ensuring the set value of the underfloor supply.





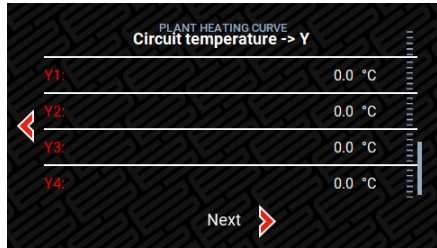
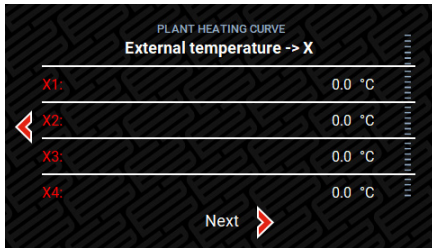

### 6.3. Procedure for performing evaporator defrosting

There are three different defrost start conditions:

- Evaporation temperature: defrosting starts when the evaporation temperature falls below the set setpoint.
- External exchanger temperature: defrosting starts when the temperature measured outside the exchanger drops below the set setpoint.
- Evaporation temperature and external exchanger temperature: both previous conditions must be met.

In addition, the value of the Interval parameter is set, which determines the minimum operating time of the device between two defrost procedures. When the conditions for the beginning of defrosting are met, the controller's internal clock starts, which will begin defrosting after the time set in the Delay parameter.

It is also possible to set different defrost onset temperatures depending on the outdoor ambient temperature. You define 5 of these temperatures at 5 ambient temperatures. The points between the declared temperatures are calculated proportionally.

The defrost ends when the condensation temperature exceeds the temperature set as End.

### 6.4. SG Ready

The JBG-2 heat pumps have the possibility to integrate with the SG Ready smart grid (SG). Based on the signals from the power grid, four operating states are realised:

- Operating state 1 (with terminal state 1:0). Indicates interlocking of the power grid operator. In this case, a forced shutdown of the heat pump is implemented.
- Operating state 2 (with terminal state 0:0). The heat pump operates as usual.
- Operating state 3 (with terminal status 0:1). Heat pump operates in boosted mode. The settings are automatically increased to the settings for the Pre-Comfort mode.
- Operating state 4 (with terminal condition 1:1). The heat pump operates in forced-on mode. The settings will automatically be increased to the settings of the Pre-Comfort mode and a request will be generated to start the heat pump.

## 7. MAINTENANCE, INSPECTION AND REPAIR

### 7.1. Maintenance notes

The heat pump is a highly automated device. Checks on the condition of the unit should be carried out regularly during its operation. If the unit is maintained effectively, its operational reliability and service life will be extended.

- 5) Users should pay attention to the use and maintenance of this device: all safety parameters in the device are set before leaving the factory, do not set them yourself.
- 6) Always check that the power supply and wiring of the device's electrical system is stable, that the electrical components are not malfunctioning, and repair and replace them in a timely manner if necessary.
- 7) Always check the proper filling of the water system, the water tank safety valve, the liquid level regulator and the air discharge device to prevent air from entering the system, thereby reducing water circulation. This may affect the heating performance and reliability of the unit's operation.
- 8) The unit should be kept clean and dry and well ventilated. Clean the air-side heat exchangers of dust and lingering leaves regularly with a vacuum cleaner. This will maintain good heat exchange. It is absolutely forbidden to wash the exchanger with a jet of liquid or pressurized gas.
- 9) Do not accumulate any unnecessary things around the unit to avoid blocking the air inlet and outlet.
- 10) If the device malfunctions and the user is unable to solve the problem, inform the company, reporting the need for service technician assistance.
- 11) Clean the housing only with a damp cloth and a small amount of solvent-free soap. Do not use aerosol agents, surface scratching agents, dishwashing liquids, or cleaning agents containing solvent or chlorine.
- 12) It is recommended to use running water to clean the evaporator of the main unit.

### 7.2. Safety parameters

- 1) If the pressure in the refrigerant circuit rises above the maximum pressure of about 26.5 bar, the pressure sensor will shut down the heat pump compressor. As soon as the pressure drops to the appropriate value, the compressor will be activated.
- 2) If the heat pump is turned on with the crankcase temperature below 7°C or after 12 hours without power, the compressor crankcase heater will turn on to prevent damage to the compressor during restarting.
- 3) If the temperature measured at the compressor output is higher than the allowed temperature - the compressor will be turned off.
- 4) The amount of water in the heating circuit is monitored by the water flow sensor. If there is a demand for heat with the circulation pump running, the water flow will not be recognized - the compressor will not start.

### 7.3. Disassembly and disposal

- 1) Be particularly careful when proceeding to disassemble the heat pump or its electrical components and subassemblies.
- 2) Disconnect the heat pump from the power supply before disassembling the unit.
- 3) After disconnecting the power supply, wait 90 seconds before opening the unit. Voltage may remain on the frequency converter during this time.
- 4) After disconnecting the pump from the power supply, the refrigerant should be released from the system in the open air.
- 5) Only persons familiar with the handling of R290 refrigerant may perform the task.
- 6) Use personal protective equipment and carry fire extinguishers.



## 7.4. Decommissioning the appliance

The decommissioning of electrical and electronic appliances should be conducted in accordance with the current national law in which the appliance was being used.

## 7.5. Error codes

Code	Description	Type	Result	Modbus
AL000	Unit - Prototype alert	Automatic reset	Unit shutdown	DI1000
AL001	Unit - Remote alarm	User reset	Unit shutdown	DI1001
AL002	Unit - Error in the number of records retained in memory	User reset	Only message	DI1002
AL003	Unit - Error in saving records in memory	User reset	Only message	DI1003
AL004	Unit - User inlet water temperature probe	Automatic reset	Disabling user adjustment (*1)	DI1004
AL005	Unit - User outlet water temperature probe	Automatic reset	Disabling user adjustment (*1)	DI1005
AL006	Unit - Source inlet water temperature probe	Automatic reset	Only message	DI1006
AL007	Unit - Outdoor temperature probe	Automatic reset	Only message	DI1007
AL008	Unit - user pump 1 overload	User reset	Disabling user adjustment	DI1008
AL009	Unit - Source pump 1 overload	User reset	Unit shutdown	DI1009
AL010	Unit - Flow switch alarm - no flow when user pump 1 is active	Automatic reset to: 5 times within 3600 s	Disabling user adjustment	DI1010
AL011	Unit - Flow switch alarm - no flow when source pump 1 is active	Automatic reset to: 5 times within 3600 s	Unit shutdown	DI1011
AL012	Unit - User pump grounding alarm	User reset	Disabling user adjustment	DI1012
AL013	Unit - User pump grounding alarm	User reset	Unit shutdown	DI1013
AL014	Unit - User 1 Pump maintenance	Automatic reset	Message only	DI1014
AL015	Unit - Source 1 pump maintenance	Automatic reset	Message only	DI1015
AL016	Unit - High temperature of chilled water	Automatic reset	Message only	DI1016
AL017	Unit - Low water temperature in tank	Automatic reset	Message only	DI1017
AL018	Unit - Low domestic hot water temperature	Automatic reset	Message only	DI1018
AL019	Unit - Anti-freeze alarm implemented in high pressure mode	Automatic reset	Message and action forced on unit	DI1019
AL020	Unit - Domestic hot water temperature probe	Automatic reset	Disabling DHW control	DI1020
AL021	Unit - Source outlet water temperature probe	Automatic reset	Message only	DI1021
AL022	Unit - Tank water temperature probe alarm	Automatic reset	Disabling user adjustment (*1)	DI1022

## INSTRUCTION MANUAL – HEAT PUMP

Code	Description	Type	Result	Modbus
AL023	Unit - General source alarm	Automatic reset to: 5 times within 3600 s	Unit shutdown	DI1023
AL024	Unit - DHW pump maintenance	Automatic reset	Message only	DI1024
AL025	Unit - Group DHW pump alarm	User reset	Disabling DHW control	DI1025
AL026	Unit - Flow switch alarm - no flow when DHW pump 1 is active	Automatic reset to: 5 times within 3600 s	Disabling DHW control	DI1026
AL027	Unit - DHW pump 1 overload	User reset	Disabling DHW control	DI1027
AL028	Unit - Outdoor coil temperature probe	Automatic reset	Message only	DI1028
AL029	Unit - User antifreeze alarm for water temperature in cooling mode	Automatic reset	forced on user pump	DI1029
AL030	Unit - User antifreeze alarm for water temperature in heating mode	Automatic reset	Compressor shutdown, forced on user pump	DI1030
AL031	Unit - Source antifreeze alarm for water temperature in cooling mode	Automatic reset	forced on user pump	DI1031
AL032	Unit - Source antifreeze alarm for water temperature in heating mode	Automatic reset	Compressor shutdown, forced on user pump	DI1032
AL033	Unit - DHW outlet water probe alarm	Automatic reset	Only message	DI1033
AL034	Unit - Offline building management system alarm	Automatic reset	Offline management of the building management system	-
AL092	Circuit 1 - Defrost interrupted by circuit alarm	Automatic reset	Only message	DI1034
AL093	Circuit 1 - Discharge pressure probe alarm	Automatic reset	Disconnecting circuit 1	DI1035
AL094	Circuit 1 - Suction pressure probe alarm	Automatic reset	Disconnecting circuit 1	DI1036
AL095	Circuit 1 - Discharge temperature probe alarm	Automatic reset	Disconnecting circuit 1	DI1037
AL096	Circuit 1 - Suction temperature probe alarm	Automatic reset	Disconnecting circuit 1	DI1038
AL097	Circuit 1 - Liquid temperature probe alarm	Automatic reset	Only message	DI1039
AL098	Circuit 1 Envelope - High compression ratio	Automatic reset	Disconnecting circuit 1	DI1040
AL099	Circuit 1 Envelope - High pressure discharge	Automatic reset to: 3 times within 3600 s	Disconnecting circuit 1	DI1041
AL100	Circuit 1 Envelope - High motor current	Automatic reset	Disconnecting circuit 1	DI1042
AL101	Circuit 1 Envelope - High suction pressure	Automatic reset	Disconnecting circuit 1	DI1043



Code	Description	Type	Result	Modbus
AL102	Circuit 1 Envelope - Low compression ratio	Automatic reset	Disconnecting circuit 1	DI1044
AL103	Circuit 1 Envelope - Low differential pressure	Automatic reset	Disconnecting circuit 1	DI1045
AL104	Circuit 1 Envelope - Low discharge pressure	Automatic reset	Disconnecting circuit 1	DI1046
AL105	Circuit 1 Envelope - Low suction pressure	Automatic reset	Disconnecting circuit 1	DI1047
AL106	Circuit 1 Envelope - High discharge temperature	Automatic reset	Disconnecting circuit 1	DI1048
AL107	Circuit 1 Expansion valve - Low overheating	Automatic reset to: 3 times within 3600 s	Disconnecting circuit 1	DI1049
AL108	Circuit 1 Expansion valve - Low evaporation pressure	Automatic reset	Disconnecting circuit 1	DI1050
AL109	Circuit 1 Expansion valve - High evaporation pressure	Automatic reset	Disconnecting circuit 1	DI1051
AL110	Circuit 1 Expansion valve - High condensation temperature	Automatic reset	Disconnecting circuit 1	DI1052
AL111	Circuit 1 Expansion valve - Low suction temperature	Automatic reset	Disconnecting circuit 1	DI1053
AL112	Circuit 1 Expansion valve - Motor error	User reset	Disconnecting circuit 1	DI1054
AL113	Circuit 1 Expansion valve - Emergency shutdown	User reset	Disconnecting circuit 1	DI1055
AL114	Circuit 1 Expansion valve - Set out of range	Automatic reset	Disconnecting circuit 1	DI1056
AL115	Circuit 1 Expansion valve - Setup range error	Automatic reset	Message only	DI1057
AL116	Circuit 1 Expansion valve - Offline	Automatic reset	Disconnecting circuit 1	DI1058
AL117	Circuit 1 Expansion valve - Low battery	Automatic reset	Message only	DI1059
AL118	Circuit 1 Expansion valve - EEPROM memory	Automatic reset	Message only	DI1060
AL119	Circuit 1 Expansion valve - Incomplete closure of the valve	Automatic reset	Disconnecting circuit 1	DI1061
AL120	Circuit 1 Expansion valve - firmware incompatible	Automatic reset	Disconnecting circuit 1	DI1062
AL121	Circuit 1 Expansion valve - Configuration error	Automatic reset	Disconnecting circuit 1	DI1063
AL122	Circuit 1 Inverter - Offline	Automatic reset	Power + circuit 1 shutdown	DI1064
AL123	Circuit 1 Inverter - Drive current overload (01)	Automatic reset	Power + circuit 1 shutdown	DI1065
AL124	Circuit 1 Inverter - Motor overload (02)	Automatic reset	Power + circuit 1 shutdown	DI1066
AL125	Circuit 1 Inverter - DC bus voltage overload (03)	Automatic reset	Power + circuit 1 shutdown	DI1067
AL126	Circuit 1 Inverter - DC bus voltage underload (04)	Automatic reset	Power + circuit 1 shutdown	DI1068

Code	Description	Type	Result	Modbus
AL127	Circuit 1 Inverter - Drive temperature overload (05)	Automatic reset	Power + circuit 1 shutdown	DI1069
AL128	Circuit 1 Inverter - Drive temperature underload (06)	Automatic reset	Power + circuit 1 shutdown	DI1070
AL129	Circuit 1 Inverter - Equipment current overload (07)	Automatic reset	Power + circuit 1 shutdown	DI1071
AL130	Circuit 1 Inverter - PTC motor temperature overload (08)	Automatic reset	Power + circuit 1 shutdown	DI1072
AL131	Circuit 1 Inverter - IGBT module error (09)	Automatic reset	Power + circuit 1 shutdown	DI1073
AL132	Circuit 1 Inverter - CPU error (10)	Automatic reset	Power + circuit 1 shutdown	DI1074
AL133	Circuit 1 Inverter - Default parameters (11)	Automatic reset	Power + circuit 1 shutdown	DI1075
AL134	Circuit 1 Inverter - DC bus ripple (12)	Automatic reset	Power + circuit 1 shutdown	DI1076
AL135	Circuit 1 Inverter - Data communication failure (13)	Automatic reset	Power + circuit 1 shutdown	DI1077
AL136	Circuit 1 Inverter - Drive thermistor error (14)	Automatic reset	Power + circuit 1 shutdown	DI1078
AL137	Circuit 1 Inverter - Failure of automatic tuning (15)	Automatic reset	Power + circuit 1 shutdown	DI1079
AL138	Circuit 1 Inverter - Drive disabled (16)	Automatic reset	Power + circuit 1 shutdown	DI1080
AL139	Circuit 1 Inverter - Motor phase error (17)	Automatic reset	Power + circuit 1 shutdown	DI1081
AL140	Circuit 1 Inverter - Internal fan error (18)	Automatic reset	Power + circuit 1 shutdown	DI1082
AL141	Circuit 1 Inverter - Speed error (19)	Automatic reset	Power + circuit 1 shutdown	DI1083
AL142	Circuit 1 Inverter - PFC module error (20)	Automatic reset	Power + circuit 1 shutdown	DI1084
AL143	Circuit 1 Inverter - PFC voltage overload (21)	Automatic reset	Power + circuit 1 shutdown	DI1085
AL144	Circuit 1 Inverter - PFC voltage underload (22)	Automatic reset	Power + circuit 1 shutdown	DI1086
AL145	Circuit 1 Inverter - STO error detection (23)	Automatic reset	Power + circuit 1 shutdown	DI1087
AL146	Circuit 1 Inverter - STO error detection (24)	Automatic reset	Power + circuit 1 shutdown	DI1088
AL147	Circuit 1 Inverter - Grounding error (25)	Automatic reset	Power + circuit 1 shutdown	DI1089
AL148	Circuit 1 Inverter - ADC conversion synchronization error (26)	Automatic reset	Power + circuit 1 shutdown	DI1090
AL149	Circuit 1 Inverter - Hardware synchronization error (27)	Automatic reset	Power + circuit 1 shutdown	DI1091
AL150	Circuit 1 Inverter - Drive overload (28)	Automatic reset	Power + circuit 1 shutdown	DI1092



Code	Description	Type	Result	Modbus
AL151	Circuit 1 Inverter - Error code (29)	Automatic reset	Power + circuit 1 shutdown	DI1093
AL152	Circuit 1 Inverter - Unexpected reboot (98)	Automatic reset	Power + circuit 1 shutdown	DI1094
AL153	Circuit 1 Inverter - Unexpected stop (99)	Automatic reset	Power + circuit 1 shutdown	DI1095
AL154	Circuit 1 Compressor - Start-up error	User reset	Power + circuit 1 shutdown	DI1096
AL155	Circuit 1 Compressor - Pressure differential greater than allowed during startup	Automatic reset	Power + circuit 1 shutdown	DI1097
AL159	Circuit 1 - User alarm freezing evaporation temperature	Automatic reset to: 3 times within 3600 s	Disconnecting circuit 1	DI1101
AL160	Circuit 1 - Compressor Maintenance 1	Automatic reset	Only message	DI1102
AL161	Circuit 1 - Compressor maintenance 2	Automatic reset	Only message	DI1103
AL162	Circuit 1 - Condensation temperature probe alarm	Automatic reset	Disconnecting circuit 1	DI1104
AL163	Circuit 1 - Fan 1 circuit 1 maintenance	Automatic reset	Only message	DI1105
AL164	Circuit 1 - Fan 2 circuit 1 maintenance	Automatic reset	Only message	DI1106
AL165	Circuit 1 - Fan 3 circuit 1 maintenance	Automatic reset	Only message	DI1107
AL166	Circuit 1 - High pressure alarm from pressure switch	Automatic reset to: 3 times within 3600 s	Disconnecting circuit 1	DI1108
AL167	Circuit 1 - Low pressure alarm from pressure switch	Automatic reset to: 3 times within 3600 s	Disconnecting circuit 1	DI1109
AL168	Circuit 1 – Compressor 1 overload	Automatic reset to: 3 times within 3600 s	Compressor shutdown 1 circuit 1	DI1110
AL169	Circuit 1 – Compressor 2 overload	User reset	Compressor shutdown 1 circuit 1	DI1111
AL170	Circuit 1 - Completion of pumping for maximum time	Automatic reset	Only message	DI1112
AL171	Circuit 1 - Evaporation freezing temperature source alarm	Automatic reset to: 3 times within 3600 s	Disconnecting circuit 1	DI1113
AL190	Circuit 2 - Defrost interrupted by circuit alarm	Automatic reset	Message only	DI1114
AL191	Circuit 2 - Discharge pressure probe alarm	Automatic reset	Disconnecting circuit 2	DI1115
AL192	Circuit 2 - Suction pressure probe alarm	Automatic reset	Disconnecting circuit 2	DI1116
AL193	Circuit 2 - Discharge temperature probe alarm	Automatic reset	Disconnecting circuit 2	DI1117
AL194	Circuit 2 - Suction temperature probe alarm	Automatic reset	Disconnecting circuit 2	DI1118
AL195	Circuit 2 - Fluid temperature probe alarm	Automatic reset	Message only	DI1119

Code	Description	Type	Result	Modbus
AL196	Circuit 2 Envelope - High compression	Automatic reset	Disconnecting circuit 2	DI1120
AL197	Circumference 2 Envelope - High discharge pressure	Automatic reset to: 3 times within 3600 s	Disconnecting circuit 2	DI1121
AL198	Circuit 2 Envelope - High motor current	Automatic reset	Disconnecting circuit 2	DI1122
AL199	Circuit 2 Envelope - High suction pressure	Automatic reset	Disconnecting circuit 2	DI1123
AL200	Circuit 2 Envelope - Low compression	Automatic reset	Disconnecting circuit 2	DI1124
AL201	Circuit 2 Envelope - Low differential pressure	Automatic reset	Disconnecting circuit 2	DI1125
AL202	Circuit 2 Envelope - Low discharge pressure	Automatic reset	Disconnecting circuit 2	DI1126
AL203	Circuit 2 Envelope - Low suction pressure	Automatic reset	Disconnecting circuit 2	DI1127
AL204	Circuit 2 Envelope - High discharge temperature	Automatic reset	Disconnecting circuit 2	DI1128
AL205	Circuit 2 Expansion valve - Low overheating	Automatic reset to: 3 times within 3600 s	Disconnecting circuit 2	DI1129
AL206	Circuit 2 Expansion valve - Low evaporation pressure	Automatic reset	Disconnecting circuit 2	DI1130
AL207	Circuit 2 Expansion valve - High evaporation pressure	Automatic reset	Disconnecting circuit 2	DI1131
AL208	Circuit 2 Expansion valve - High condensation temperature	Automatic reset	Disconnecting circuit 2	DI1132
AL209	Circuit 2 Expansion valve - Low suction temperature	Automatic reset	Disconnecting circuit 2	DI1133
AL210	Circuit 2 Expansion valve - Motor error	Automatic reset	Disconnecting circuit 2	DI1134
AL211	Circuit 2 Expansion valve - Emergency shutdown	Automatic reset	Disconnecting circuit 2	DI1135
AL212	Circuit 2 Expansion valve - Set out of range	Automatic reset	Disconnecting circuit 2	DI1136
AL213	Circuit 2 Expansion valve - Settings range error	Automatic reset	Message only	DI1137
AL214	Circuit 2 Expansion valve - Offline	Automatic reset	Disconnecting circuit 2	DI1138
AL215	Circuit 2 Expansion valve - Low battery state of charge	Automatic reset	Message only	DI1139
AL216	Circuit 2 Expansion valve - EEPROM memory	Automatic reset	Message only	DI1140
AL217	Circuit 2 Expansion valve - Incomplete closure of the valve	Automatic reset	Disconnecting circuit 2	DI1141
AL218	Circuit 2 Expansion valve - Firmware incompatible	Automatic reset	Disconnecting circuit 2	DI1142
AL219	Circuit 2 Expansion valve - Configuration error	Automatic reset	Disconnecting circuit 2	DI1143





Code	Description	Type	Result	Modbus
AL220	Circuit 2 Inverter - Offline	Automatic reset	Power + circuit 2 shutdown	DI1144
AL221	Circuit 2 Inverter - Drive current overload (01)	Automatic reset	Power + circuit 2 shutdown	DI1145
AL222	Circuit 2 Inverter - Motor overload (02)	Automatic reset	Power + circuit 2 shutdown	DI1146
AL223	Circuit 2 Inverter - DC bus voltage overload (03)	Automatic reset	Power + circuit 2 shutdown	DI1147
AL224	Circuit 2 Inverter - DC bus voltage underload (04)	Automatic reset	Power + circuit 2 shutdown	DI1148
AL225	Circuit 2 Inverter - Drive temperature overload (05)	Automatic reset	Shutdown of power + circuit 2	DI1149
AL226	Circuit 2 Inverter - Drive temperature underload (06)	Automatic reset	Power + circuit 2 shutdown	DI1150
AL227	Circuit 2 Inverter - Equipment current overload (07)	Automatic reset	Power + circuit 2 shutdown	DI1151
AL228	Circuit 2 Inverter - PTC motor temperature overload (08)	Automatic reset	Power + circuit 2 shutdown	DI1152
AL229	Circuit 2 Inverter - IGBT module error (09)	Automatic reset	Power + circuit 2 shutdown	DI1153
AL230	Circuit 2 Inverter - CPU error (10)	Automatic reset	Power + circuit 2 shutdown	DI1154
AL231	Circuit 2 Inverter - Default parameters (11)	Automatic reset	Power + circuit 2 shutdown	DI1155
<p>=&gt; Note: Please ensure the following options:                      + (*): The meaning of the inputs changes according to the configured type of control, this probe will only be available if the user has selected inlet water temperature control.</p>				

Errors and safety alertsThe device must not be operated and serviced by unauthorized persons who do not have experience or knowledge in operating the above-mentioned device!

### Heat pump startup checklist

### HEAT PUMP INSTALLATION

Was the device installed according to the instructions  YES\*

#### Indoor Unit:

Installation site is dry and protected from frost  YES\*

Installation spacing is maintained  YES\*

The unit has been leveled  YES\*

#### Outdoor Unit:

Installation spacing is maintained  YES\*

The unit has been leveled  YES\*

Ground mounting  YES\*, height above ground: .....cm

Type of assembly: stand + rubber feet  YES / optional rubber base  YES

Acoustic separation (the water system does not transmit vibrations to the building structure)  YES\*

#### Outdoor Unit – Protective Area:

Dimension of the protective area in accordance with the requirements of the installation instructions  YES\*

No openings in the building (windows, vent openings, doors, etc.)  YES\*

No open lines in the sewer system, or cavities where escaping refrigerant could accumulate  YES\*

No ignition sources (lamps, electrical sockets, lights, etc.)  YES\*

#### Condensate drainage:

No direct connection to the sewer system  YES\*

Gravel ballast/absorbent substrate  YES\*

Heating wire inserted into the condensate drain funnel and connected  YES\*

No siphons in the condensate drainage  YES\*

Condensate drain protected from frost  YES\*

Checking the drainage of condensate flow  YES\*

\* - mandatory fields - condition for starting up the device



## HEATING SYSTEM

**Heating circuit installation:**

Installation in accordance with the manufacturer's recommendations  YES\*

New installation       Upgraded installation

Heating type: floor heating  / radiators  / other

Correctly connected supply and return pipes of central heating circuits  YES\*

Safety valve has been installed  YES\*

Outer pipes in UV- and high-temperature-resistant insulation  YES\*

Thickness of external pipe insulation according to the requirements ( $\lambda \leq 0,035$ ):  YES\*

- inner diameter of the pipe less than 22 mm - insulation thickness of 20 mm;
- inner diameter of the pipe from 22 to 35 mm - insulation thickness 30 mm;
- inner pipe from 35 to 100 mm - insulation thickness equal to the inner diameter of the pipe;
- inner pipe more than 100 mm - insulation thickness of 100 mm.

Dirt filter installed on the return of the heating system  YES\*

Installed magneto-demulsifier on the return of the heating system  YES\*

The minimum water charge necessary for proper operation and defrosting of the outdoor unit is provided  YES\*

The minimum required water flow through the system has been ensured  YES\*, it is ..... [l/min]

An expansion vessel was installed, the capacity of the vessel ..... L  YES\*

Additional vent valves  YES ..... units

Shut-off valves on the supply  on the return

Drain valves on the supply \* on the return \*

Number of heating circuits  one  two

**Water in the central heating + DHW system** (according to the installer's statement)

Heating water quality in accordance with the requirements of the instructions  YES\*

Heating system pressure ..... bar

Checked for leaks in the installation  YES\*

The installation was flushed prior to connecting the equipment  YES\*

Installation filled and vented  YES\*

DHW safety group installed  YES\*

Checking the correct operation of the water pump and the direction of flow  YES\*

\* - mandatory fields - condition for starting up the device

### **System separation:**

Heat exchanger installed  YES  NO If yes:

Type of antifreeze medium in the heat pump circuit: .....

Freezing point .....°C

Heat pump circuit vented  YES\*

Heat pump circuit pressure ..... bar

Connecting the buffer in parallel  / in series

### **Notes:**

## ELECTRICAL INSTALLATION

All electrical connections of modules and devices were routed according to the diagram  YES\*

Electrical wires protected inside the electrical box against pulling out  YES\*

Access to the electrical system, circuit breakers and protection is provided  YES\*

Protective and grounding wires connected  YES\*

Temperature sensors connected according to the instructions  YES\*

Control wires and sensors routed at a distance of min. 100mm from power wires  YES\*

Correct 3-phase power cable used min. 5 x 4mm<sup>2</sup>  \*/\*\*

The correct overcurrent circuit breakers were used for the units:

- ZHHS-01-10K-R290-V5: 10A C characteristics, 3-phase, 3L + N  YES\*

- ZHHS-01-15K-R290-V5: 16A C characteristics, 3-phase, 3L + N  YES\*

In both cases for the controller: overcurrent circuit breaker 6A characteristic B, 1-phase, 1L + N  YES\*

Differential protection used:  YES\*\*\* TYPE .....

In case of option with a heater:

An overcurrent circuit breaker for the heater was used: 16A characteristic B, 3-phase, 3L + N  YES\*

### **Notes:**

\* - mandatory fields - condition for starting up the device

\*\* - the wire should be selected according to the parameters of the fuse used



## SETTINGS, COMMISSIONING, HANDOVER TO USER

Quick guide successfully completed  YES\*

Operating mode set  CH /  CH+DHW /  DHW

Target temperature set CH: heating curve  / fixed value .....°C

Target temperature set of DHW: fixed value .....°C

Additional heat source  none  dry contact  integrated heater

Bivalent point C.H. ....°C

DHW bivalent point .....°C

### Handover to User

Heat pump operation instruction  YES\*

Safety instructions on R290 refrigerant  YES\*

Function and location of safety devices  YES\*

Information on regular maintenance and inspections  YES\*

Instructions and product documentation have been provided  YES\*

.....  
Installer

.....  
Person executing launch

.....  
Customer

\* - mandatory fields - condition for starting up the device







PRODUCER OF PROFESSIONAL REFRIGERATION EQUIPMENT

**Siedziba główna / Produkcja**  
Headquarter / Factory

43-254 Warszowice  
ul. Gajowa 5  
Poland

**Produkcja**  
Factory

43-240 Żory  
al. Jana Pawła II 46  
Poland

**Sekretariat**  
Secretariat

+48 32 494 00 00  
info@jbg2.com



**PRZEDSTAWICIEL REGIONALNY**  
REGIONAL REPRESENTATIVE

**jbg2.com**